

COMPETENCE BASED CURRICULUM

SENIOR SCHOOL

GRADE 10

GRADE GUIDE NOTES

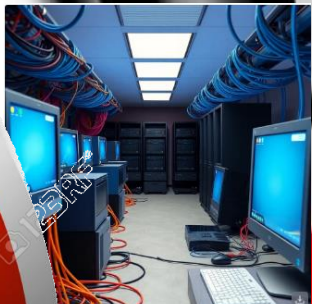
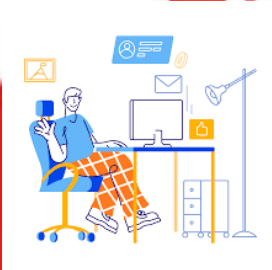

LAN, MAN, WAN SETUP

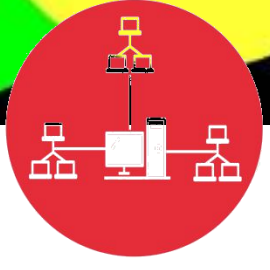





Communication and
Collaboration



Critical Thinking
and Problem
Solving



Digital
Literacy

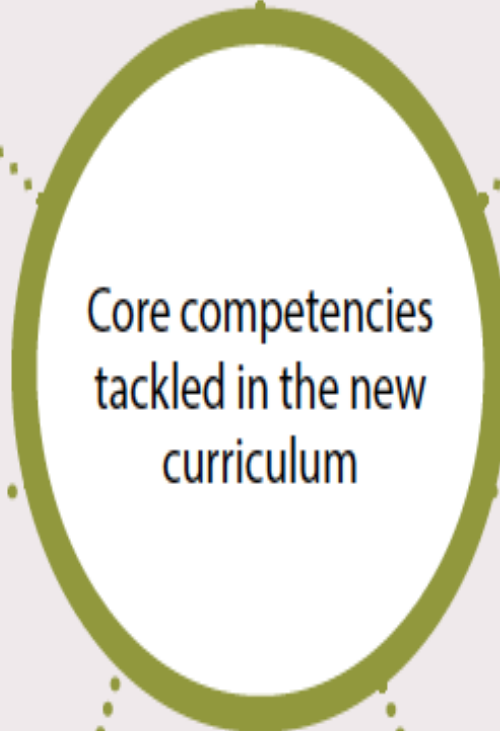

Citizenship



Imagination and
Creativity



New Kenya Basic Education Curriculum Framework

2 - 6 - 6 - 3

Pre - Primary School - 2 Yrs.

Pre-Primary 1

Pre-Primary 2

Formative Assessment

Lower Primary School - 3 Yrs.

Grade 1

Grade 2

Grade 3

Formative Assessment and
National Assessment

Upper Primary School - 3 Yrs.

Grade 4

Grade 5

Grade 6

Formative Assessment and
National Assessment

Lower Secondary School - 3 Yrs.

Grade 7

Grade 8

Grade 9

Formative Assessment and
National Assessment

Senior Secondary School - 3 Yrs.

Grade 10

Grade 11

Grade 12

Formative Assessment and
National Assessment

Tertiary and Higher Education
3 Years

Formative Assessments - Ongoing throughout term/semester

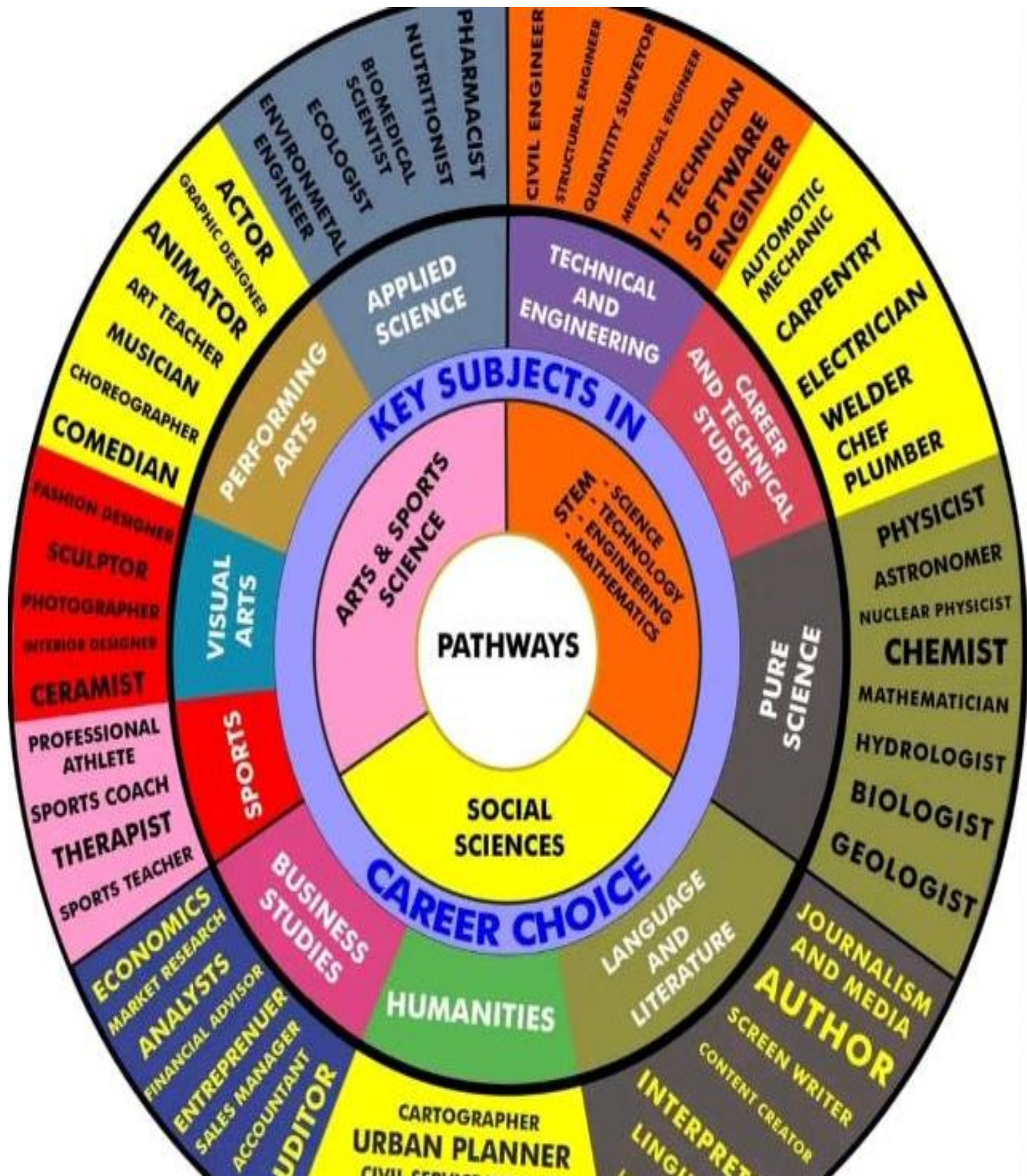

NATIONAL GOALS OF EDUCATION

Education in Kenya should:

1. Foster nationalism and patriotism and promote national unity

Kenya's people belong to different communities, races and religions, but these differences need not divide them. They must be able to live and interact as Kenyans. It is a paramount duty of education to help young people acquire this sense of nationhood by removing conflicts and promoting positive attitudes of mutual respect which enable them to live together in harmony and foster patriotism in order to make a positive contribution to the life of the nation.

2. Promote the social, economic, technological and industrial needs for national development

Education should prepare the youth of the country to play an effective and productive role in the life of the nation.

a) Social Needs

Education in Kenya must prepare children for changes in attitudes and relationships which are necessary for the smooth progress of a rapidly developing modern economy. There is bound to be a silent social revolution following in the wake of rapid modernization. Education should assist our youth to adapt to this change.

b) Economic Needs

Education in Kenya should produce citizens with the skills, knowledge, expertise and personal qualities that are required to support a growing economy. Kenya is building up a modern and independent economy which is in need of an adequate and relevant domestic workforce.

c) Technological and Industrial Needs

Education in Kenya should provide learners with the necessary skills and attitudes for industrial development. Kenya recognizes the rapid industrial and technological changes taking place, especially in the developed world. We can only be part of this development if our education system is deliberately focused on the knowledge, skills and attitudes that will prepare our young people for these changing global trends.

3. Promote individual development and self-fulfilment

Education should provide opportunities for the fullest development of individual talents and personality. It should help children to develop their potential interests and abilities. A vital aspect of individual development is the building of character.

4. Promote sound moral and religious values

Education should provide for the development of knowledge, skills and attitudes that will enhance the acquisition of sound moral values and help children to grow up into self-disciplined, self-reliant and integrated citizens.

5. Promote social equity and responsibility

Education should promote social equality and foster a sense of social responsibility within an education system which provides equal educational opportunities for all. It should give all children varied and challenging opportunities for collective activities and corporate social service irrespective of gender, ability or geographical environment.

6. Promote respect for and development of Kenya's rich and varied cultures

Education should instill in the youth of Kenya an understanding of past and present cultures and their valid place in contemporary society. Children should be able to blend the best of traditional values with the changing requirements that must follow rapid development in order to build a stable and modern society.

7. Promote international consciousness and foster positive attitudes towards other nations

Kenya is part of the international community. It is part of the complicated and interdependent network of peoples and nations. Education should therefore lead the youth of the country to accept membership of this international community with all the obligations and responsibilities, rights and benefits that this membership entails.

8. Promote positive attitudes towards good health and environmental protection

Education should inculcate in young people the value of good health in order for them to avoid indulging in activities that will lead to physical or mental ill health. It should foster positive attitudes towards environmental development and conservation. It should lead the youth of Kenya to appreciate the need for a healthy environment.

LEARNING OUTCOMES FOR SENIOR SCHOOL

By the end of senior school, the learner should be able to:

1. Communicate effectively and utilize information and communication technology across varied contexts,
2. Apply mathematical, logical and critical thinking skills for problem solving,
3. Apply basic research and scientific skills to manipulate the environment and solve problems,
4. Exploit individual talents for leisure, self-fulfillment, career growth, further education and training,
5. Uphold national, moral and religious values and apply them in day-to-day life,
6. Apply and promote health care strategies in day-to-day life,
7. Protect, preserve and improve the environment for sustainability,
8. Demonstrate active local and global citizenship for harmonious co-existence,
9. Demonstrate appreciation of diversity in people and cultures,
10. Manage pertinent and contemporary issues responsibly.

THE SENIOR SCHOOL IN THE COMPETENCY BASED CURRICULUM (CBC)

Senior School is the fourth level of Basic Education in the Competency Based Curriculum (CBC) that learners shall come to after the Pre-Primary, Primary and Junior School (JS). The essence of Senior School is to offer learners a Pre- University/ Pre- career experience where the learners have an opportunity to choose pathways where they have demonstrated interest and/or potential at the earlier levels. Senior school comprises three years of education for learners in the age bracket of 15 to 18 years and lays the foundation for further education and training at the tertiary level and the world of work. In the CBC vision, learners exiting this level are expected to be engaged, empowered and ethical citizens ready to participate in the socio-economic development of the nation.

At this level, learners shall take SEVEN (07) learning areas (LAs) as recommended by the Presidential Working Party on Educational Reforms (PWPER). These shall comprise Four Compulsory learning areas, and Three learning areas opted for by the learner according to their chosen Pathway. While English and Kiswahili are indicated as Compulsory, the learners who opt for these learning areas as their subjects of specialization shall go through a differentiated curriculum in terms of scope, experiences and assessment. Such learners shall; therefore, take Advanced English or Kiswahili Kipevu with additional two lessons. It is recommended that AT LEAST TWO learning areas should be from chosen Pathway. In exceptional cases, some learners may opt for ONE learning area from the chosen Pathway and a maximum of TWO learning areas from any of the three pathways; depending.

LIST OF LEARNING AREAS AT SENIOR SCHOOL

LIST OF SUBJECTS AT SENIOR SCHOOL

Core Subjects	Arts & Sports Science	Social Sciences	Science, Technology, Engineering & Mathematics (STEM)
1. English 2. Kiswahili/KSL 3. Core Mathematics/ Essential Mathematics 4. Physical Education (PE)	5. Sports and Recreation 6. Music and Dance 7. Theatre and Film 8. Fine Arts	9. Literature in English 10. Indigenous Languages 11. Fasihi ya Kiswahili 12. Sign Language 13. Arabic 14. French 15. German 16. Mandarin Chinese 17. Christian Religious Education 18. Islamic Religious Education 19. Hindu Religious Education 20. Business Studies 21. History and Citizenship 22. Geography	23. Biology 24. Chemistry 25. Physics 26. General Science 27. Agriculture 28. Computer Studies 29. Home Science 30. Aviation Technology 31. Building Construction 32. Electrical Technology 33. Metal Technology 34. Power Mechanics 35. Wood Technology 36. Media Technology 37. Marine and Fisheries Technology

ESSENCE STATEMENT

The Computer Science curriculum at Senior School aims to equip a learner with competencies, skills and attitudes in computing principles, concepts and techniques. The competencies acquired will enable a learner to design, implement and manage computing systems that provide social, economic, industrial and technological solutions for national development. The curriculum design encompasses theoretical and practical aspects of foundations of computer science, computer networking and software development. These aspects will equip a learner with problem-solving, critical thinking and analytical skills through learner centred, experiential and inquiry-based learning approaches. The curriculum design is intended for a learner who would like to pursue a professional career in Computer Science or related disciplines.

This learning area is anchored on National Goals of Education No. 2 which aims to provide the learners with the necessary skills and attitudes for industrial development, Kenya Vision 2030 on making education responsive to education needs, Sessional Paper No 1 of 2019, which recommended the promotion of technical and vocational education with an emphasis on Science, Technology, and Innovation (ST&I) in the school curriculum. It is also informed by the second pillar of Africa Agenda 2063 and the National ICT Policy of Kenya 2016 (revised 2020), which emphasises on use of ICT as a foundation for the creation of a more robust economy.

GENERAL SUBJECT LEARNING OUTCOMES

By the end of Senior Secondary School, the learner should be able to:

- a) Use knowledge, skills and values acquired in computer science to perform daily life activities.
- b) Practise ethical and safe use of computer technology in society.
- c) Develop computer applications for solving real world problems.
- d) Configure and manage computer networks for effective resource sharing.
- e) Initiate career and entrepreneurship opportunities in the field of computer science.
- f) Adapt to the dynamic digital world to cope with the changing needs of the society.

SUMMARY OF STRANDS AND SUB STRANDS

1.0 FOUNDATION OF COMPUTER SCIENCE

- 1.1 Evolution of Computers
- 1.2 Computer Architecture
- 1.3 Input/Output (I/O) Devices
- 1.4 Computer storage
- 1.5 Central Processing Unit (CPU)
- 1.6 Operating System (OS)
- 1.7 Computer setup

2.0 COMPUTER NETWORKING

- 2.1 Data communication
- 2.2 Data Transmission Media

2.3 Computer Network Elements

2.4 Network Topologies

3.0: SOFTWARE DEVELOPMENT

3.1 Computer Programming Concepts

3.2 Program development

3.3 Identifiers and Operators

3.4 Control Structures

3.5 Containers

3.6 Functions

STRAND 1.0: FOUNDATION OF COMPUTER SCIENCE

SUB-STRAND 1.1: EVOLUTION AND DEVELOPMENT OF COMPUTERS

1.1.1 Early Computing Devices (Relating to Electronic Computers)

These early tools, though not electronic, introduced fundamental concepts in computation and paved the way for the development of modern computers.

(a) Ancient and Medieval Computing Devices:

✓ Abacus (Around 2400 BC):

Description: A manual calculating tool consisting of beads arranged on rods or wires, representing place values. Operators manipulate the beads to perform arithmetic operations.

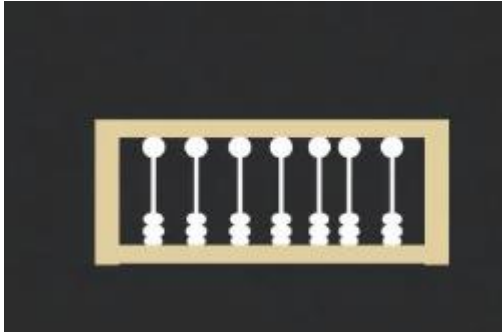

(Simplified Abacus Representation)

An image showing a traditional abacus with beads on rods.

- ✚ **Relation to Evolution:** Introduced the concept of representing numbers using physical objects and performing calculations through manipulation, a basic form of data processing.
- ✓ **Napier's Bones (Early 17th Century):**
 - ✚ **Description:** A set of numbered rods used for multiplication and division. The rods contained pre-calculated multiples of numbers, simplifying complex calculations.

Image:

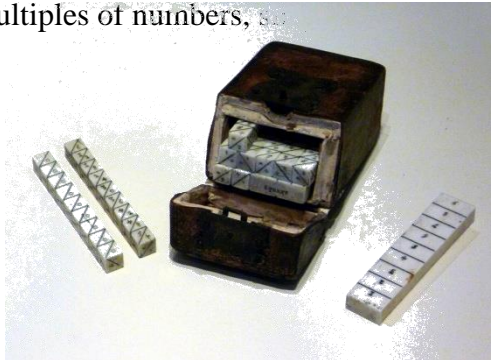

An illustration of a set of Napier's Bones.

- ✚ **Relation to Evolution:** Demonstrated the idea of using pre-calculated information and structured tools to simplify complex mathematical tasks, a step towards automation.
- ✓ **Pascaline (1642):**
 - ✚ **Description:** The first mechanical calculator capable of addition and subtraction. It used a system of gears and dials to represent numbers and perform calculations automatically.



A photograph of Blaise Pascal's mechanical calculator, the Pascaline.

- ✚ **Relation to Evolution:** Marked a significant step towards automated calculation using mechanical principles, a precursor to the electromechanical devices.
- ✓ **Slide Rule (Around 1620):**
 - ✚ **Description:** An analog computer used primarily for multiplication and division, and also for functions such as roots, logarithms, and trigonometry. It uses two logarithmic scales that slide against each other.

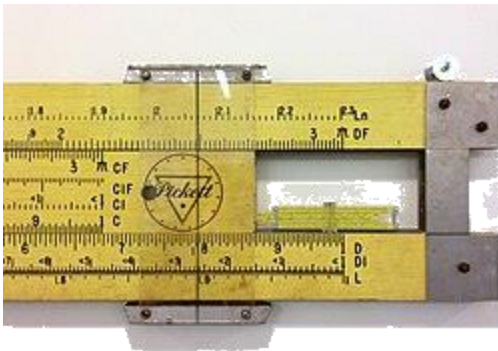

Difference Engine (Early 19th Century):

- **Description:** A mechanical calculator designed by Charles Babbage to automatically calculate polynomial functions. It was intended to produce accurate mathematical tables, eliminating errors from manual calculation.

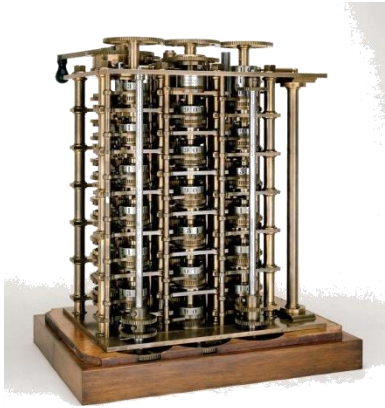

Difference Engine No. 1.

- **Relation to Evolution:** Introduced concepts like automated computation based on a program (though fixed), mechanical memory for intermediate results, and the idea of a machine performing complex tasks autonomously.
- ✓ **Analytic Engine (Mid-19th Century):**
 - **Description:** Also designed by Charles Babbage, this was a more ambitious general-purpose mechanical computer. It included components analogous to a modern computer: an arithmetic unit ("mill"), a control unit, memory ("store"), and input/output mechanisms (based on punched cards). Although never fully built in Babbage's lifetime, its design was revolutionary.

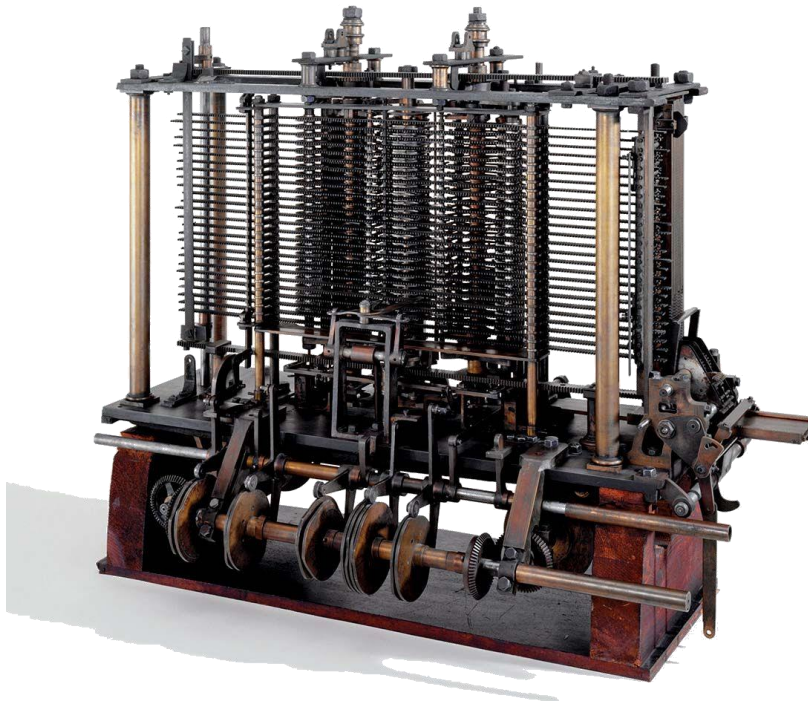

A diagram illustrating the conceptual architecture of the Analytic Engine.

- **Relation to Evolution:** Considered the theoretical precursor to the modern digital computer. It introduced the fundamental architectural concepts of input, processing, storage, and output, along with the idea of programmable computation. Ada Lovelace is considered the first computer programmer for her work on the Analytic Engine.
- ✓ **Jacquard Loom (Early 19th Century):**
 - **Description:** A mechanical loom that used punched cards to control the weaving of intricate patterns in textiles automatically. The holes in the cards determined which warp threads were raised or lowered for each pass of the shuttle.

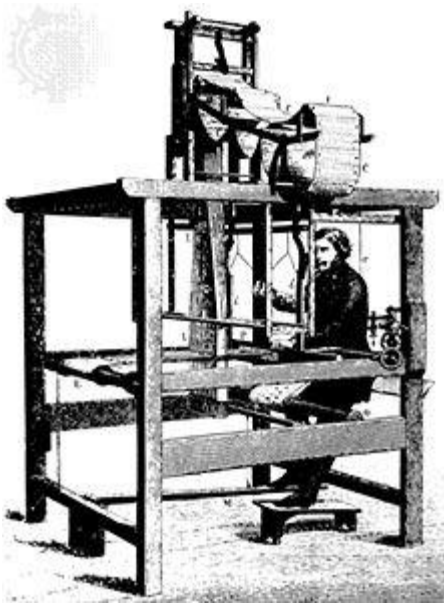

A close-up of the mechanism of a Jacquard Loom using punched cards.

- **Relation to Evolution:** Introduced the concept of using punched cards as a form of programmable instruction and data storage, which later influenced input methods for early computers.

1.1.2 Principle Technologies Defining Computer Development

The evolution of computers is marked by breakthroughs in fundamental electronic technologies.

(b) Principle Technologies:

- **Vacuum Tubes (Early to Mid-20th Century):**
 - ✚ **Description:** Electronic devices that control the flow of electric current in a high vacuum between electrodes. They were used as switches and amplifiers in the first generation of electronic computers.



A schematic diagram of a triode vacuum tube.

- ✚ **Impact:** Enabled the development of electronic computers by providing a way to perform calculations electronically. However, they were large, consumed a lot of power, generated significant heat, and were unreliable due to frequent burnouts.
- **Transistors (Mid-20th Century):**
 - ✚ **Description:** Semiconductor devices that can switch and amplify electronic signals. They replaced vacuum tubes due to their smaller size, lower power consumption, less heat generation, higher speed, and greater reliability.

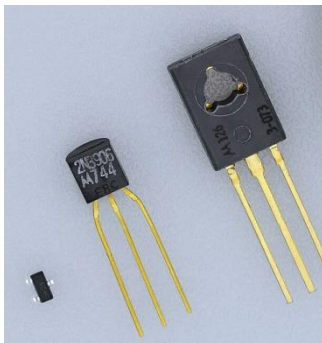

A photograph of a small transistor.

- ✚ **Impact:** Ushered in the second generation of computers, making them smaller, faster, more energy-efficient, and more reliable. This was a crucial step towards the personal computer era.
- **Integrated Circuits (ICs) - Small Scale Integration (SSI) and Medium Scale Integration (MSI) (Late 20th Century):**
 - ✚ **Description:** A single semiconductor chip containing many interconnected electronic components (transistors, resistors, capacitors, etc.). SSI typically contained a few transistors, while MSI contained hundreds.

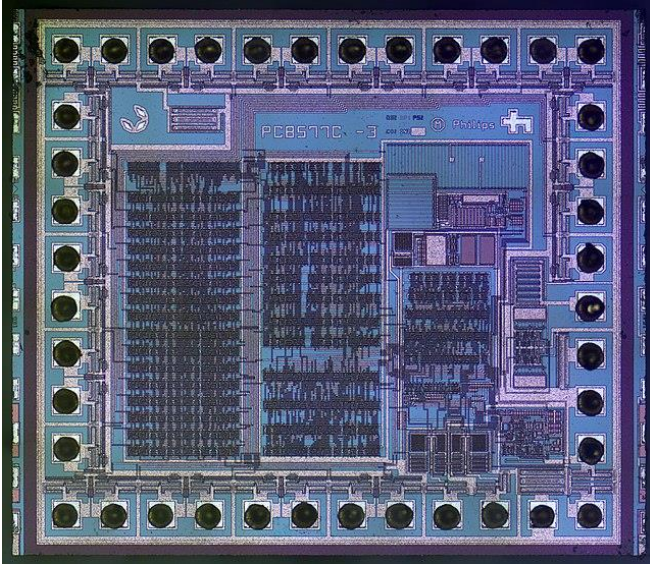

A photograph of a Dual In-line Package (DIP) integrated circuit.

- ✚ **Impact:** Led to the third generation of computers. ICs further reduced the size, cost, and increased the speed and efficiency of computers. More complex circuits could be manufactured on a single chip, leading to more powerful machines.
- **Large Scale Integration (LSI) and Very Large Scale Integration (VLSI) (Late 20th Century - Present):**
 - ✚ **Description:** Advanced IC technologies that allowed for the integration of thousands (LSI) and then millions (VLSI) of transistors onto a single chip. Microprocessors (the entire CPU on a single chip) became possible with VLSI.



A photograph of an Intel 486DX2 microprocessor chip.

- ✚ **Impact:** Revolutionized computing, leading to the development of powerful microprocessors, personal computers, laptops, and eventually the smartphones and tablets we use today. VLSI

continues to drive miniaturization, increased processing power, and reduced costs in modern electronics (fourth and fifth generations).

1.1.3 Computer Generations and Principle Technologies

Each generation of computers is characterized by the dominant technology used in their construction.

(c) Relating Principle Technologies to Computer Generation:

Generation	Approximate Period	Principal Technology	Key Characteristics	Examples
First	1940s - 1950s	Vacuum Tubes	Large size, high power consumption, significant heat, low reliability, slow speed.	ENIAC, UNIVAC I
Second	1950s - 1960s	Transistors	Smaller size, lower power consumption, less heat, higher reliability, faster speed.	IBM 1401, PDP-1
Third	1960s - 1970s	Integrated Circuits (SSI/MSI)	Further reduction in size and cost, increased speed and efficiency, more reliable.	IBM System/360, DEC PDP-8
Fourth	1970s - Present	Large Scale Integration (LSI) & Very Large Scale Integration (VLSI)	Microprocessors, personal computers, high processing power, small size, low cost.	Apple Macintosh, IBM PC, Modern Laptops and Desktops
Fifth	Present and Beyond	Artificial Intelligence, Parallel Processing, Superconductors, Quantum Computing	Focus on AI, parallel processing, natural language understanding, advanced computing.	AI systems, Supercomputers, Quantum Computers (in development)

1.1.4 Technological Advancement in Computer Development

(d) Appreciating Technological Advancement:

The progression through computer generations demonstrates remarkable technological advancement:

- ✓ **Miniaturization:** Computers have shrunk from room-sized machines to handheld devices, thanks to the increasing density of integrated circuits.
- ✓ **Increased Processing Power:** Each new technology has enabled faster and more complex calculations, leading to the powerful computing capabilities we have today.
- ✓ **Improved Efficiency:** Newer technologies consume less power and generate less heat, making computers more energy-efficient and reliable.
- ✓ **Reduced Cost:** Mass production of advanced components like microprocessors has significantly lowered the cost of computing, making it accessible to a wider population.

- ✓ **Enhanced Reliability:** Solid-state components like transistors and integrated circuits are far more reliable than their predecessors, leading to fewer hardware failures.
- ✓ **New Capabilities:** The advancements have paved the way for entirely new applications and fields, such as the internet, multimedia, artificial intelligence, and data science.

SUB-STRAND 1.2: COMPUTER ORGANISATION AND ARCHITECTURE

1.2.1 Von Neumann Computer Architecture

The von Neumann architecture is a computer architecture based on a description by the mathematician and physicist John von Neumann and others in the "First Draft of a Report on the EDVAC" (1945). It is the foundation of most modern computers.

(a) Functional Organisation of a von Neumann Computer:

A von Neumann architecture has five main functional units:

1. **Input Unit:** Devices used to feed data and instructions into the computer. Examples include the keyboard, mouse, scanner, microphone, etc.

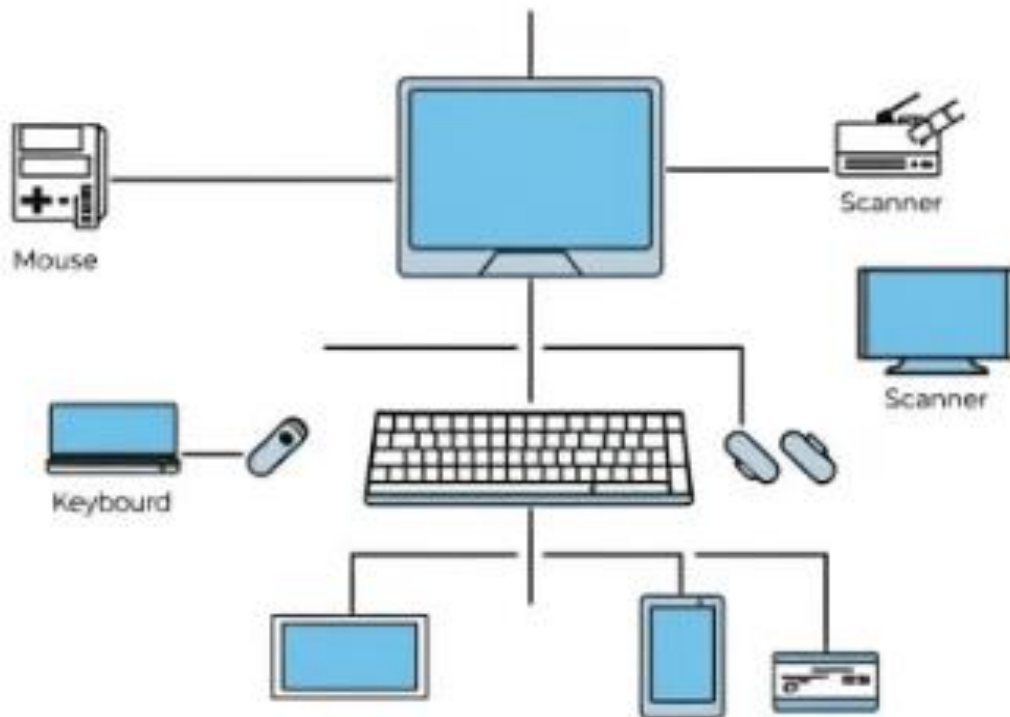

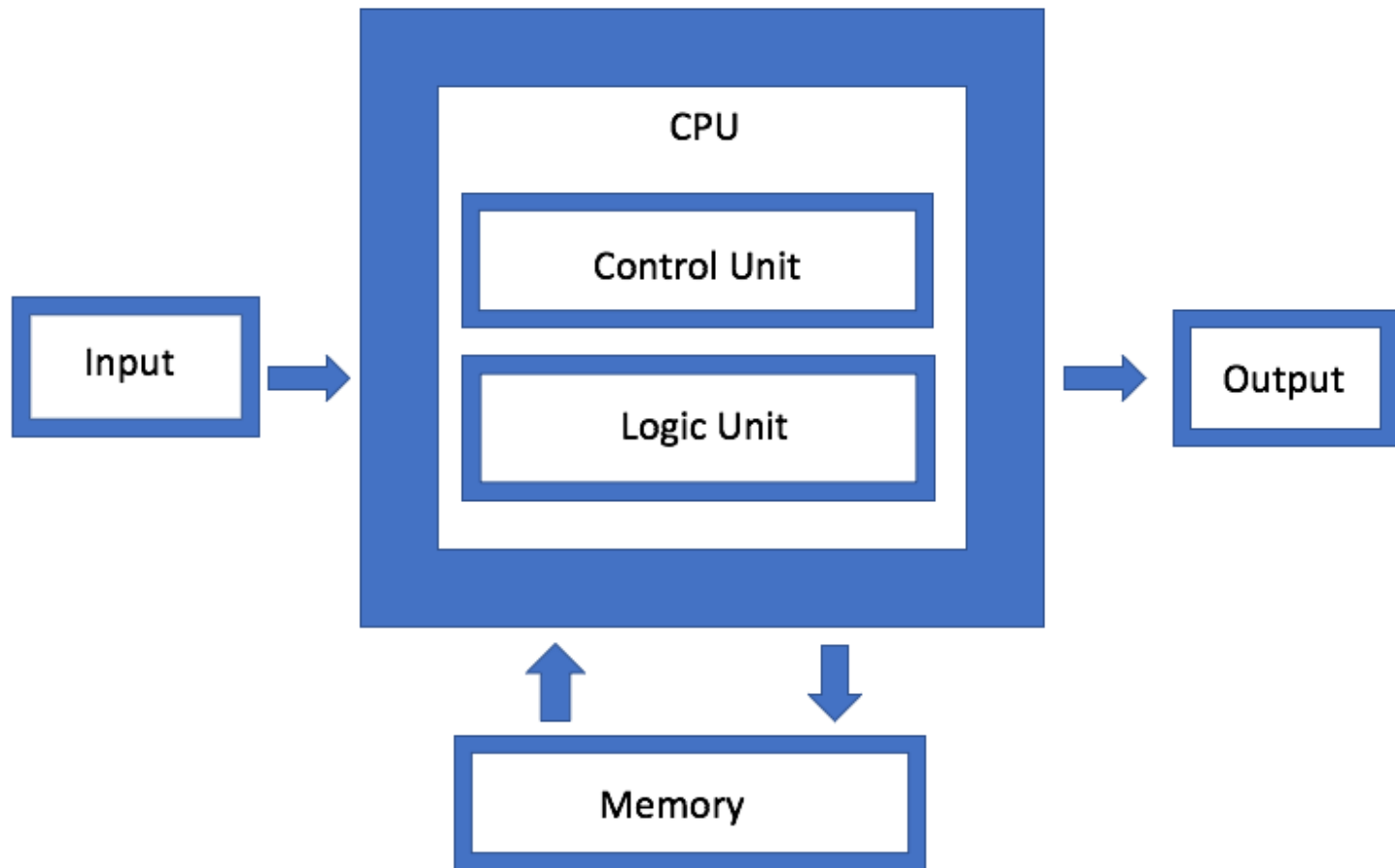

A diagram showing various input devices.

2. **Central Processing Unit (CPU):** The "brain" of the computer, responsible for executing instructions. It consists of two main parts:
 - ✓ **Arithmetic Logic Unit (ALU):** Performs arithmetic calculations (addition, subtraction, multiplication, division) and logical operations (AND, OR, NOT).
 - ✓ **Control Unit (CU):** Manages and coordinates all the activities of the computer. It fetches instructions from memory, decodes them, and sends control signals to other units to execute them.

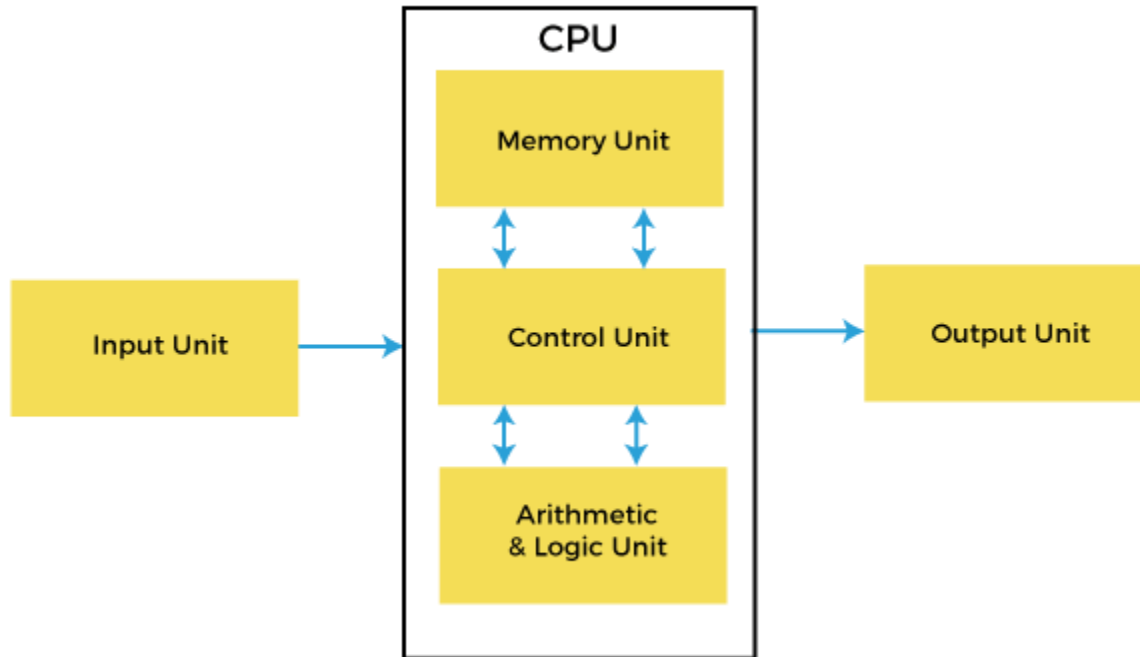

A simplified block diagram of a Central Processing Unit.

3. **Memory Unit:** Stores data and instructions that are currently being processed or will be processed. In a von Neumann architecture, a single address space is used for both instructions and data. This is a key characteristic.
 - ✓ **Main Memory (RAM):** Random Access Memory - volatile memory that stores data and instructions actively being used.
 - ✓ **Secondary Storage (Hard Disk, SSD):** Non-volatile memory used for long-term storage of data and programs.



A picture of a RAM module.

4. **Output Unit:** Devices that display or present the processed information to the user. Examples include the monitor, printer, speakers, etc.



A diagram showing various output devices.

5. **Buses:** Sets of electrical conductors that transmit data, addresses, and control signals between the different components of the computer. There are three main types of buses:
- ✓ **Data Bus:** Carries data between the CPU, memory, and other peripherals.
 - ✓ **Address Bus:** Carries the memory addresses from the CPU to the memory to specify the location being accessed.
 - ✓ **Control Bus:** Carries control signals from the control unit to other components to coordinate their actions.

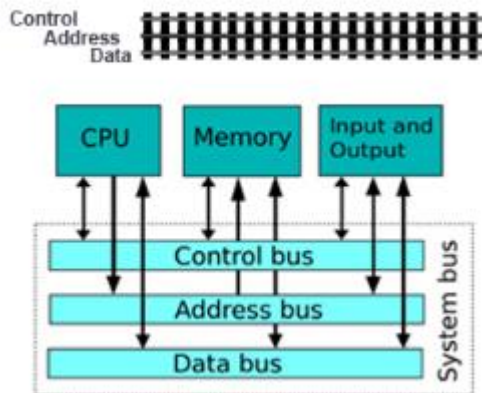

A diagram illustrating the data, address, and control buses.

(b) Relationships Among Functional Elements:

The functional elements work together in a coordinated manner to execute programs:

1. **Input:** The user provides data and instructions through input devices.
2. **Storage:** The input data and instructions are stored in the memory unit.
3. **Processing:**
 - ✓ The **Control Unit (CU)** fetches instructions from the memory.

- ✓ The **CU** decodes the instruction.
 - ✓ The **CU** sends control signals to the **Arithmetic Logic Unit (ALU)** and other components.
 - ✓ The **ALU** performs the arithmetic or logical operations on the data fetched from memory.
 - ✓ The results are stored back in the memory.
4. **Output:** The processed information (results) is retrieved from the memory and sent to the output unit to be displayed or presented to the user.
 5. **Communication via Buses:** All these operations rely on the buses for transferring data, addresses of memory locations, and control signals between the different units.

(c) Model of a Computer Architecture:

You can create a simple model using locally available materials like cardboard, wires, and labels to represent the different components and their connections.

- ✓ **Cardboard boxes/sections:** Represent the CPU, Memory Unit, Input Unit, and Output Unit.
- ✓ **Wires/drawn lines:** Represent the data bus, address bus, and control bus connecting the components.
- ✓ **Labels:** Clearly label each component (CPU, ALU, CU, Memory, Input, Output) and the buses.
- ✓ **Arrows:** Indicate the direction of data flow and control signals.

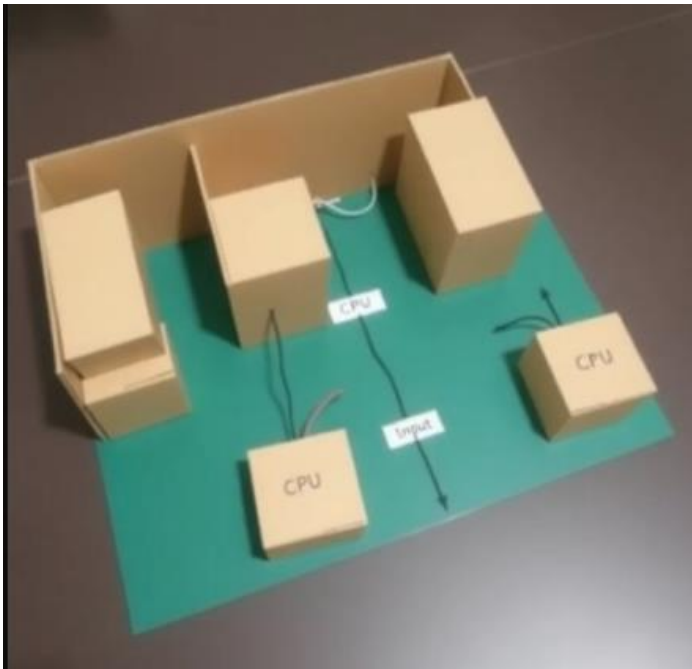

A basic block diagram representing the von Neumann architecture.

1.2.2 Data Representation in a Von Neumann Computer

Digital computers, based on the von Neumann architecture, use binary numbers to represent all types of data and instructions. Other number systems like octal and hexadecimal are often used as a more human-readable shorthand for binary.

(d) Using Binary, Octal, and Hexadecimal Number Systems:

• **Binary Number System (Base-2):**

- ✓ Uses only two digits: 0 and 1 (bits).
- ✓ The fundamental language of computers because electronic circuits can easily represent these two states (on/off, high/low voltage).
- ✓ **Conversion from Base-10 to Binary:** Repeatedly divide the decimal number by 2 and record the remainders in reverse order.

Example:

Convert 13 (base-10) to binary: $13 \div 2 = 6$ remainder **1** $6 \div 2 = 3$ remainder **0** $3 \div 2 = 1$ remainder **1** $1 \div 2 = 0$ remainder **1** So, $13_{10} = 1101_2$

- ✓ **Conversion from Binary to Base-10:** Multiply each bit by the corresponding power of 2 and sum the results.

Example:

Convert 10110_2 to base-10: $(1 \times 2^4) + (0 \times 2^3) + (1 \times 2^2) + (1 \times 2^1) + (0 \times 2^0) = 16 + 0 + 4 + 2 + 0 = 22_{10}$

• **Octal Number System (Base-8):**

- ✓ Uses eight digits: 0, 1, 2, 3, 4, 5, 6, 7.
- ✓ Often used as a shorthand for binary because each octal digit can be represented by exactly three binary digits.
- ✓ **Conversion from Base-10 to Octal:**

Repeatedly divide the decimal number by 8 and record the remainders in reverse order.

Example:

Convert 26 (base-10) to octal: $26 \div 8 = 3$ remainder **2** $3 \div 8 = 0$ remainder **3** So, $26_{10} = 32_{8}$

- ✓ **Conversion from Octal to Base-10:**

Multiply each digit by the corresponding power of 8 and sum the results.

Example: Convert 45_{8} to base-10: $(4 \times 8^1) + (5 \times 8^0) = 32 + 5 = 37_{10}$

- ✓ **Conversion between Binary and Octal:** Group binary digits in threes from the right and convert each group to its octal equivalent.

Example: Binary 110101_2 to octal: Group: 110 101 Octal: 6 5 $\Rightarrow 65_{8}$

• **Hexadecimal Number System (Base-16):**

- ✓ Uses sixteen symbols: 0, 1, 2, 3, 4, 5, 6, 7, 8, 9, A, B, C, D, E, F (where A=10, B=11, C=12, D=13, E=14, F=15).
- ✓ Widely used in computing to represent memory addresses and data in a more compact and human-readable form than binary. Each hexadecimal digit can be represented by exactly four binary digits.
- ✓ **Conversion from Base-10 to Hexadecimal:** Repeatedly divide the decimal number by 16 and record the remainders (converting remainders 10-15 to A-F) in reverse order.

Example: Convert 42 (base-10) to hexadecimal: $42 \div 16 = 2$ remainder **10 (A)** $2 \div 16 = 0$ remainder **2** So, $42_{10} = 2A_{16}$

- ✓ **Conversion from Hexadecimal to Base-10:** Multiply each digit by the corresponding power of 16 and sum the results.

Example: Convert $1F_{16}$ to base-10: $(1 \times 16^1) + (F \times 16^0) = (1 \times 16) + (15 \times 1) = 16 + 15 = 31_{10}$

- ✓ **Conversion between Binary and Hexadecimal:** Group binary digits in fours from the right and convert each group to its hexadecimal equivalent.

Example: Binary 11110010_2 to hexadecimal: Group: 1111 0010 Hex: F 2 $\Rightarrow F2_{16}$

- **Table Summarizing Number Systems:**

Octal Number	Binary Numbers		
	A	B	C
0	0	0	0
1	0	0	1
2	0	1	0
3	0	1	1
4	1	0	0
5	1	0	1
6	1	1	0
7	1	1	1

(e) Importance of Computer Architecture in Computing:

Computer architecture plays a crucial role in determining the performance, efficiency, and capabilities of a computer system.

- **Performance:** The architecture, including the design of the CPU, memory hierarchy, and bus system, directly impacts how quickly instructions are executed and data is processed.
- **Efficiency:** A well-designed architecture optimizes the use of resources like power and memory, leading to more energy-efficient systems.
- **Functionality:** The architecture dictates the types of instructions the computer can execute and the way it handles data, influencing the software that can run on it.
- **Scalability:** A good architecture allows for easier upgrades and expansion of the system.
- **Cost:** Different architectural choices can affect the cost of manufacturing and ultimately the price of the computer.

SUB-STRAND 1.3: INPUT/OUTPUT (I/O) DEVICES

1.3.1 Types of Input Devices

Input devices are hardware peripherals used to send data and control signals to a computer for processing.

(a) Types of Input Devices:

- **Keying Devices:** These devices allow users to input data by pressing keys.
 - **Keyboard:** The most common input device, used to enter text, numbers, and commands by pressing keys corresponding to letters, numbers, symbols, and functions.



A picture of a standard computer keyboard.

- **Numeric Keypad:** A smaller set of keys, usually on the right side of a keyboard, used for efficient numeric data entry.



A close-up of a numeric keypad.

- **Pointing Devices:** These devices control the movement of a cursor or pointer on the screen to make selections and interact with graphical user interfaces (GUIs).
 - **Mouse:** A handheld device that detects motion relative to a surface. Buttons on the mouse allow for clicking, double-clicking, and dragging. Some mice have a scroll wheel for vertical scrolling.

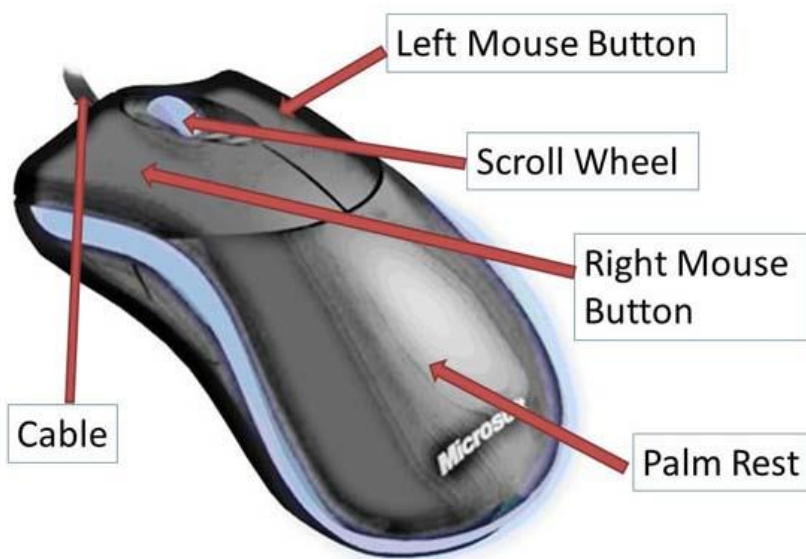

!

- **Trackball:** A stationary device with a ball that the user rotates to move the cursor.



Surface found on laptops. Users move their fingers across the surface to control the cursor.

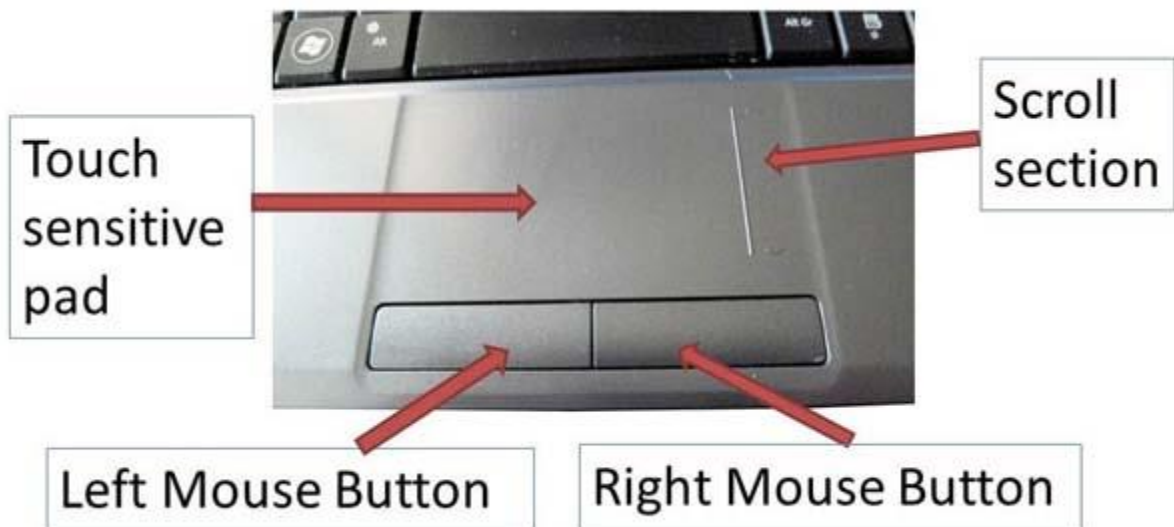

- **Joystick:** A stick that pivots on a base and reports its angle or direction to the device it is controlling. Commonly used for gaming.



A picture of a computer joystick.

- **Light Pen:** A light-sensitive stylus used to point at objects on a CRT monitor.



An illustration of a light pen.

- **Scanning Devices:** These devices convert physical documents or objects into digital images.
 - **Scanner (Flatbed Scanner):** A device that scans documents or photos placed on a glass bed.



Flatbed scanner.

- **Barcode Reader:** An optical scanner that reads barcodes (a series of parallel lines representing data).



A picture of a handheld barcode reader scanning a barcode.

- **Quick Response (QR) Code Reader:** A device or software that scans QR codes (two-dimensional barcodes) containing various types of information (URLs, text, contact details). Smartphones often have built-in QR code readers.



- **Two-Dimensional (2D) Scanner:** Scans flat objects and captures data in two dimensions (length and width). Flatbed scanners are a common type.



- **Three-Dimensional (3D) Scanner:** Captures the shape and size of a physical object in three dimensions (length, width, and depth), creating a digital 3D model.



▪

An illustration of a 3D scanner scanning an object.

- **Voice Input Devices:** These devices allow users to input data or commands using their voice.
 - **Microphone:** Converts sound waves into electrical signals that can be processed by a computer. Often used with speech recognition software.



- **Touch Screens:** Display screens that are also sensitive to touch, allowing users to interact directly with the displayed content using their fingers or a stylus.
 - **Resistive Touch Screen:** Consists of layers of electrically conductive material. Pressure on the screen causes these layers to touch, registering the input. Less sensitive to light scratches but requires actual physical pressure.

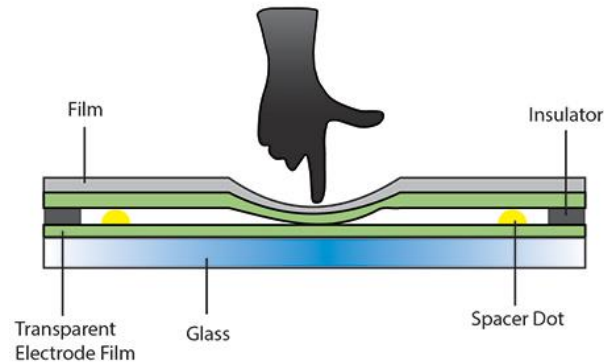

A cross-section diagram of a resistive touch screen.

- **Capacitive Touch Screen:** Uses a layer of conductive material that creates an electrical field. Touch from a finger (which is also conductive) disrupts this field, and the location of the touch is detected. More sensitive and supports multi-touch but can be affected by gloves.

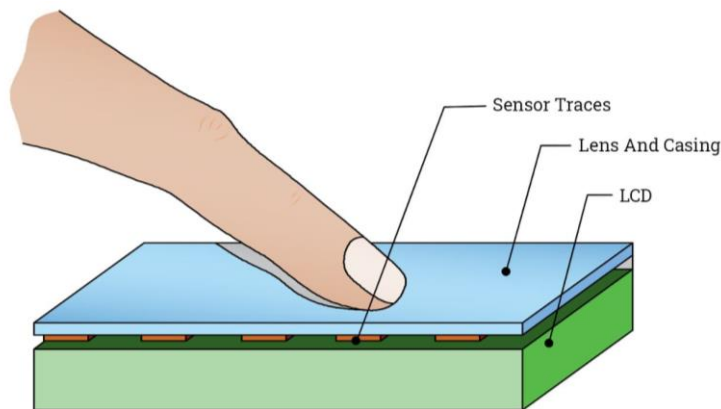

A simplified diagram of a capacitive touch screen.

- **Infra-red (IR) Touch Screen:** Uses infrared beams and sensors around the edges of the screen. When the screen is touched, the beams are interrupted, and the sensors detect the location of the break. Good optical clarity but can be affected by dust or debris.



A conceptual diagram of an infrared touch screen.

- **Digitizer (Graphics Tablet):** A flat surface on which the user draws or writes using a stylus. The tablet converts the pen movements into digital signals. Often used for graphic design and digital art.



A picture of a graphics tablet with a stylus.

- **Digital Cameras:** Capture still images and videos digitally. These can then be transferred to a computer for editing, storage, or sharing.



1.3.2 Types of Output Devices

Output devices display, print, or otherwise present information processed by the computer to the user.

(a) Types of Output Devices:

- **Monitors:** Display visual information from the computer.
 - **CRT (Cathode Ray Tube) Monitor:** Older technology that uses electron beams to create images on a fluorescent screen. Bulky and power-hungry.



A picture of an old CRT monitor.

- **LCD (Liquid Crystal Display) Monitor:** Uses liquid crystals to control the passage of light and create images. Thinner and more energy-efficient than CRTs.



LCD

A picture of a modern LCD monitor.

- **LED (Light Emitting Diode) Monitor:** A type of LCD monitor that uses LEDs for backlighting, offering better energy efficiency and color accuracy.

A picture of an LED monitor.

- **Printers:** Produce hard copies (printed documents) of digital information.
 - **Inkjet Printer:** Sprays tiny droplets of ink onto paper to create images and text. Suitable for home and small office use, good for color printing.



LED

A picture of an inkjet printer.

- **Laser Printer:** Uses a laser beam to create an electrostatic image on a drum, which then attracts toner (powdered ink). The toner is transferred to paper and fused by heat. Faster and more cost-effective for high-volume black and white printing.



▪

A picture of a laser printer.

- **Dot Matrix Printer:** Uses a print head containing pins that strike an ink ribbon to create characters as a series of dots. Older technology, noisy, but can print on multi-part forms.



▪

A picture of a dot matrix printer.

- **Speakers:** Produce audio output from the computer.



A picture of a pair of computer speakers.

- **Projectors:** Display computer output onto a large screen or wall, suitable for presentations and home theaters.



A picture of a digital projector.

- **Plotters:** Specialized output devices used for printing large-format graphics, such as architectural drawings and engineering designs.

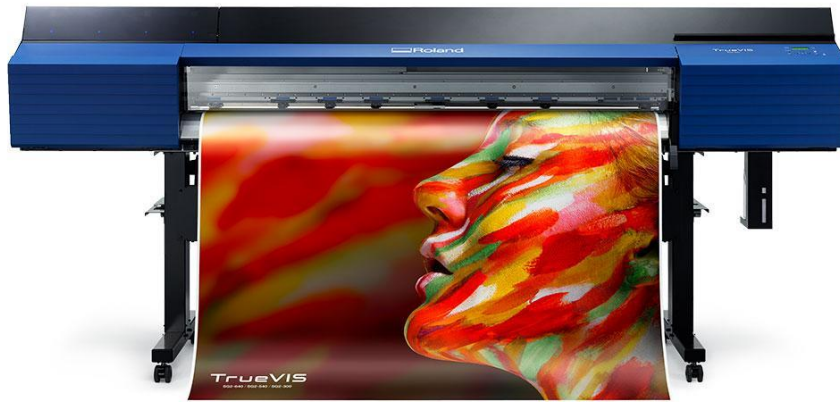

A picture of a large-format plotter.

- **Actuator:** An output device that produces physical movement based on signals from the computer. Used in robotics, automation, and control systems. Examples include motors, solenoids, and robotic arms.



A picture of a robotic arm, illustrating an actuator in action.

1.3.3 Operation of Input and Output Devices

(b) Methods of Data Entry and Information Output:

- **Methods Used by Input Devices to Enter Data:**
 - **Manual Keying:** Users type data using keyboards or numeric keypads.
 - **Pointing and Clicking:** Users use mice, trackballs, or touchpads to select options and interact with the GUI.
 - **Scanning:** Devices like scanners and barcode readers convert physical information into digital data.
 - **Voice Recognition:** Microphones capture audio, and speech recognition software converts it into text or commands.
 - **Touch Input:** Touch screens detect physical contact to register selections and gestures.
 - **Digital Image Capture:** Digital cameras and video cameras convert visual information into digital formats.
 - **Stylus Input:** Digitizers and touch screens with styluses allow for precise drawing and handwriting input.
 - **QR Code Scanning:** QR code readers decode the information embedded in QR codes.

SUB-STRAND 1.4: COMPUTER STORAGE

1.4.1 Types and Categories of Computer Storage

Computer storage refers to the various ways data and instructions are held within a computer system.

(a) Identify Types of Storage:

Learners likely have experience with various storage devices such as:

- USB flash drives
- Memory cards (SD cards)
- Hard disk drives (in desktop computers)
- Solid-state drives (in newer laptops and desktops)
- CDs and DVDs
- Cloud storage (like Google Drive, Dropbox)

(b) Categorise Types of Storage:

Computer storage is broadly categorised into two main types:

1. **Primary Storage (Main Memory):** This is the computer's main workspace. It is directly accessible by the CPU and holds the data and instructions that the CPU is currently processing. Primary storage is typically volatile, meaning data is lost when the power is turned off.
 - **RAM (Random Access Memory):** The primary working memory of the computer. It allows data to be read and written quickly, enabling the CPU to access information rapidly.
 - **Types of RAM Technology:**
 - ✓ **DRAM (Dynamic RAM):** Stores each bit of data in a separate capacitor within an integrated circuit. It needs to be periodically refreshed (re-written) to maintain the data because capacitors leak their charge over time. DRAM is cheaper and has higher storage capacities compared to SRAM.

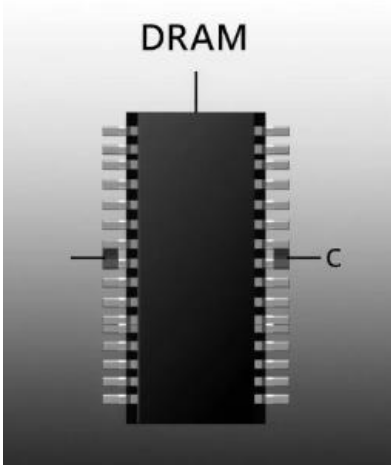

A simplified diagram of a DRAM memory cell showing a transistor and a capacitor.

- ✓ **SRAM (Static RAM):** Stores each bit of data using a flip-flop circuit (a type of latching circuit). SRAM does not need to be refreshed as long as power is supplied, making it faster than DRAM. However, it is more expensive and has lower storage capacities for the same physical size. SRAM is often used for CPU caches.

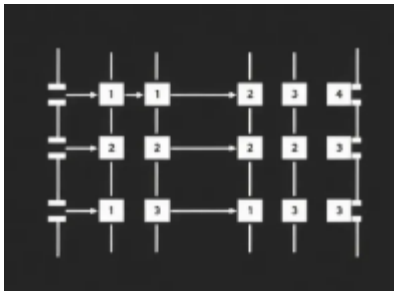

A simplified diagram of an SRAM memory cell showing transistors in a flip-flop configuration.

▪ **Differences between DRAM and SRAM:**

Feature	DRAM (Dynamic RAM)	SRAM (Static RAM)
Memory Cell	1 capacitor + 1 transistor	4-6 transistors (typically 6) forming a flip-flop
Data Storage	Charge stored in a capacitor	State of a flip-flop (transistor-based latch)
Refresh Requirement	Requires periodic refreshing (hundreds of times per second)	Does not require refreshing as long as power is supplied
Speed	Slower access time	Faster access time
Power Consumption	Lower power consumption (generally)	Higher power consumption (especially during active states)
Density	Higher density (more bits per chip)	Lower density (fewer bits per chip for the same area)
Cost	Less expensive per bit	More expensive per bit
Complexity	Simpler cell structure, but complex refresh circuitry	More complex cell structure, simpler control circuitry

Size	Smaller cell size	Larger cell size
Latency	Higher latency	Lower latency
Usage	Main memory (RAM) in computers, graphics memory (as GDDR), etc.	Cache memory (L1, L2, L3) in CPUs, high-speed buffers
Volatility	Volatile (data lost when power is off)	Volatile (data lost when power is off)
Data Retention	Requires constant power and refreshing to retain data	Retains data as long as power is supplied
Heat Generation	Lower heat generation (generally)	Higher heat generation (especially during active states)
Scalability	More scalable for large capacities	Less scalable for very large capacities
Noise Sensitivity	More susceptible to electrical noise	Less susceptible to electrical noise

- **ROM (Read-Only Memory):** A type of memory that stores data permanently or semi-permanently. The data in ROM is typically written during the manufacturing process and cannot be easily modified or erased by the user during normal computer operation. ROM is non-volatile, meaning it retains its data even when the power is off.
 - **Features of ROM Chips:**
 - ✓ **Non-volatile:** Retains data without power.
 - ✓ **Read-only (in most basic forms):** Data cannot be easily altered.
 - ✓ Contains essential software like the BIOS (Basic Input/Output System) which boots the computer.
 - **Types of ROM Technology:**
 - ✓ **PROM (Programmable ROM):** Can be written to once after manufacturing using a special device.
 - ✓ **EPROM (Erasable Programmable ROM):** Can be erased by exposing it to strong ultraviolet light and then reprogrammed.
 - ✓ **EEPROM (Electrically Erasable Programmable ROM):** Can be erased and reprogrammed electrically, making it more convenient than EPROM. Flash memory (used in USB drives and SSDs) is a type of EEPROM.
 - **Differences between RAM and ROM Chips:**

Feature	RAM (Random Access Memory)	ROM (Read-Only Memory)
Acronym	RAM	ROM
Full Form	Random Access Memory	Read-Only Memory
Volatility	Volatile (data lost when power is off)	Non-volatile (data retained when power is off)
Read/Write	Read and Write operations	Primarily Read operations (some types can be written to, but not in typical use)
Primary Use	Temporary storage for actively used data, running applications, operating system	Permanent storage for boot instructions (BIOS/UEFI), firmware
Data Access	Random access (any memory location can be accessed directly and quickly)	Random access (reading is generally fast)
Speed	Faster read and write speeds	Slower read speeds compared to RAM
Capacity	Higher capacity (typically measured in GB)	Lower capacity (typically measured in MB for basic ROM)
Cost	More expensive per bit	Less expensive per bit
Complexity	More complex circuitry	Simpler circuitry
Typical	System memory slots on the motherboard	Directly on the motherboard, in embedded systems

Location		
Modifiability	Data can be easily written, modified, and erased	Data is generally fixed after manufacturing (some types can be reprogrammed with special procedures)
Data Retention	Requires power to retain data	Retains data even without power
Examples	DDR4, DDR5 memory modules, SRAM, DRAM	BIOS chip, firmware in embedded devices, older game cartridges

ROM and RAM in Other Devices: ROM stores the firmware that controls the basic operations of devices like microwave ovens (controls cooking cycles), refrigerators (controls temperature), and remote-controlled toys/aeroplanes (controls movement and functions). RAM in these devices might be used for temporary data during operation, though it's less prominent than in computers.

2. **Secondary Storage (Auxiliary Storage):** This is used for long-term storage of data and programs that are not currently being used by the CPU. Secondary storage is typically non-volatile.
 - **Internal Secondary Storage:** Storage devices located inside the computer case.
 - **Hard Disk Drive (HDD):** A traditional storage device that uses magnetic platters to store data. Data is read and written by read/write heads that move across the spinning platters.



An image showing the internal components of a hard disk drive, including platters and read/write heads.

Solid State Drive (SSD): A newer type of storage device that uses flash memory chips to store data. SSDs have no moving parts, making them faster, more durable, and more energy-efficient than HDDs.



✓

An image showing the internal components of a solid-state drive, including controller and memory chips.

- **External Secondary Storage:** Storage devices that are connected to the computer externally.
 - **DVD/CD and DVD-RAM:** Optical storage media that use lasers to read and write data on discs. CDs have lower storage capacity than DVDs. DVD-RAM is a rewritable DVD format.



A cross-section diagram showing the layers of a CD/DVD.

- **Blu-ray Disc:** Another optical storage medium with a higher storage capacity than DVDs, used for high-definition video and large data files.



A cross-section diagram showing the layers of a Blu-ray disc.

USB Memory Stick/Flash Memory: Small, portable storage devices that connect to a computer via a USB port. They use flash memory for data storage.



A picture of a USB flash drive.

Removable Hard Drive: External hard disk drives that connect to a computer via USB or other interfaces. Offer large storage capacities and portability.



A picture of an external hard drive connected to a computer.

(c) & (d) Reading and Writing Data:

- **Reading Data:** The process of accessing and retrieving information stored on a storage device.
 - ✓ For magnetic media (HDD), read/write heads move to the correct location on the platter and sense the magnetic patterns representing data.
 - ✓ For optical media (CD/DVD/Blu-ray), a laser beam is directed at the disc, and the reflected light is interpreted as data.
 - ✓ For solid-state media (SSD/USB drive), electrical signals are used to access the data stored in the flash memory cells.
- **Writing Data:** The process of storing information onto a storage device.
 - ✓ For magnetic media (HDD), the read/write heads alter the magnetic orientation of the particles on the platter's surface to represent data.
 - ✓ For optical media (recordable discs), a laser beam burns or alters the reflective layer of the disc.
 - ✓ For solid-state media (SSD/USB drive), electrical charges are applied to the flash memory cells to store data.

(e) Criteria for Selecting Computer Storage:

When choosing a storage device, several factors need to be considered:

- ✚ **Capacity:** The amount of data the device can hold (measured in GB or TB).
- ✚ **Speed:** How quickly data can be read from and written to the device (important for performance). SSDs are generally faster than HDDs.
- ✚ **Portability:** How easy it is to carry the device around (important for external storage). USB drives are very portable, while internal HDDs are not.
- ✚ **Durability/Robustness:** How resistant the device is to physical damage (important for mobile use). SSDs are more durable than HDDs due to the absence of moving parts.
- ✚ **Cost:** The price of the storage device per unit of storage (e.g., cost per GB). HDDs are generally cheaper per GB than SSDs.

- ✚ **Security:** Features related to data protection, such as encryption capabilities.
- ✚ **Form Factor:** The physical size and shape of the device, which must be compatible with the computer system.

(f) Safety of Data in Computer Storage Media:

Protecting data stored on computer media is crucial. This involves:

- ✓ **Physical Security:** Protecting storage devices from physical damage, theft, or unauthorized access.
- ✓ **Data Backup:** Regularly creating copies of important data and storing them on separate storage devices or in the cloud.
- ✓ **Access Control:** Using passwords, encryption, and permissions to control who can access the data.
- ✓ **Data Encryption:** Encoding data so that it is unreadable without the correct decryption key. This is especially important for sensitive information and portable storage devices.
- ✓ **Safe Removal:** Properly ejecting external storage devices before physically disconnecting them to prevent data corruption.
- ✓ **Handling Precautions:** Avoiding extreme temperatures, humidity, and magnetic fields that can damage storage media.

1.4.2 Remote Storage (Cloud Storage)

Remote storage, often referred to as cloud storage, involves storing digital data on a network of servers, typically managed by a third-party provider, rather than directly on your computer or local storage device.

- **Meaning of Remote Storage:** Data is stored on distant servers and accessed via the internet. Users can upload, download, and manage their files from any device with an internet connection.
- **Examples of Remote Storage:**
 - ✓ Google Drive
 - ✓ Dropbox
 - ✓ Microsoft OneDrive
 - ✓ iCloud
 - ✓ Amazon S3
- **Saving and Retrieving Data from Remote Storage:** Users typically use web browsers or dedicated applications to upload (save) files to the remote servers and download (retrieve) them.
- **Safety of Data in Remote Computer Storage (Key Inquiry Question):**

The safety of data in remote storage is usually guaranteed through a combination of measures implemented by the service providers:

- ✓ **Encryption:** Data is often encrypted both during transmission (when uploading or downloading) and at rest (while stored on the servers). This makes it difficult for unauthorized individuals to access the data even if they intercept it or gain access to the servers.
- ✓ **Redundancy:** Data is typically replicated across multiple servers and even different data centers. This ensures that if one server or location experiences a failure, the data remains accessible from other locations.

- ✓ **Physical Security of Data Centers:** Data centers where the servers are housed have stringent physical security measures, including surveillance, access control, and environmental controls.
 - ✓ **Access Control and Authentication:** Users are required to authenticate their identity (e.g., with usernames and passwords, multi-factor authentication) before they can access their data. Providers also implement access controls to ensure that users can only access their own data.
 - ✓ **Security Protocols and Firewalls:** Robust security protocols and firewalls are used to protect the servers and the data from cyber threats, such as hacking and malware.
 - ✓ **Compliance and Certifications:** Reputable cloud storage providers often adhere to industry standards and certifications related to data security and privacy.
 - ✓ **Regular Backups:** Providers typically perform regular backups of the data stored on their servers, allowing for recovery in case of data loss.
 - ✓ **Terms of Service and Privacy Policies:** Users should review the provider's terms of service and privacy policies to understand how their data is handled and protected.
- **Advantages and Disadvantages of Different Types of Secondary Storage:**

Storage Type	Advantages	Disadvantages
HDD (Hard Disk Drive)	High capacity, relatively low cost per GB	Slower speed (read/write), less durable (susceptible to mechanical failure), higher power use, generates noise
SSD (Solid State Drive)	Very fast speed (read/write), highly durable (no moving parts), lower power consumption, silent operation, lower latency	More expensive per GB, lower capacity compared to HDDs for the same price (at the same price point), write endurance limitations (though improving)
CD/DVD	Portable, inexpensive for distribution	Low storage capacity, susceptible to scratches, relatively slow read speeds
Blu-ray Disc	High storage capacity, suitable for HD video	Less universally compatible than DVDs/CDs, read/write drives can be more expensive, slower write speeds compared to HDDs/SSDs
USB Flash Drive	Very portable, relatively fast (USB 3.0+), durable (no moving parts), plug-and-play	Limited capacity compared to HDDs/SSDs, easily lost, write endurance limitations (though less of a concern for typical use)
Removable Hard Drive	High capacity, portable	Less durable than SSDs, requires external power in some cases, slower speed compared to internal HDDs/SSDs
Remote (Cloud) Storage	Accessibility from anywhere with internet, automatic backups, collaboration features, scalability	Requires internet connection, security and privacy concerns, subscription costs, dependence on third-party providers, potential latency issues

- **Benefits of Remote Storage vs. Local Computer Storage:**

Feature	Remote Storage	Local Computer Storage
Accessibility	Accessible from any device with internet	Accessible only from the device or local network
Data Backup	Often automatic and redundant	Requires manual setup and management
Collaboration	Easy sharing and collaboration on files	More complex sharing
Data Security	Provided by the service provider (can be robust)	User responsibility (can be vulnerable)
Scalability	Easy to increase storage capacity as needed	Requires purchasing and installing new hardware
Device Independence	Data not tied to a specific physical device	Data tied to the local device
Cost	Subscription fees may apply	Initial hardware cost

Internet Needed	Requires internet connection for access	No internet needed for access
Control	Less direct control over physical storage	Full control over physical storage
Disaster Recovery	Often built-in redundancy and recovery options	User responsibility for implementing recovery strategies
Maintenance	Handled by the service provider	User responsibility for hardware and software maintenance
Synchronization	Automatic syncing across multiple devices	Requires manual syncing or third-party solutions

- **Safety Precautions When Handling Computer Storage:**
 - ✓ Handle storage devices gently to avoid physical damage.
 - ✓ Keep storage devices away from extreme temperatures, humidity, and strong magnetic fields.
 - ✓ Use antivirus software to protect against malware that can

SUB-STRAND 1.5: CENTRAL PROCESSING UNIT (CPU)

1.5.1 Structural Elements of the CPU

The Central Processing Unit (CPU) is the core component of a computer that interprets and executes instructions. It is often referred to as the "brain" of the computer.

(a) Describe Structural Elements of the CPU:

The CPU primarily consists of the following key structural elements:

- **Arithmetic and Logic Unit (ALU):** This is the part of the CPU that performs arithmetic calculations (addition, subtraction, multiplication, division) and logical operations (AND, OR, NOT, comparisons).

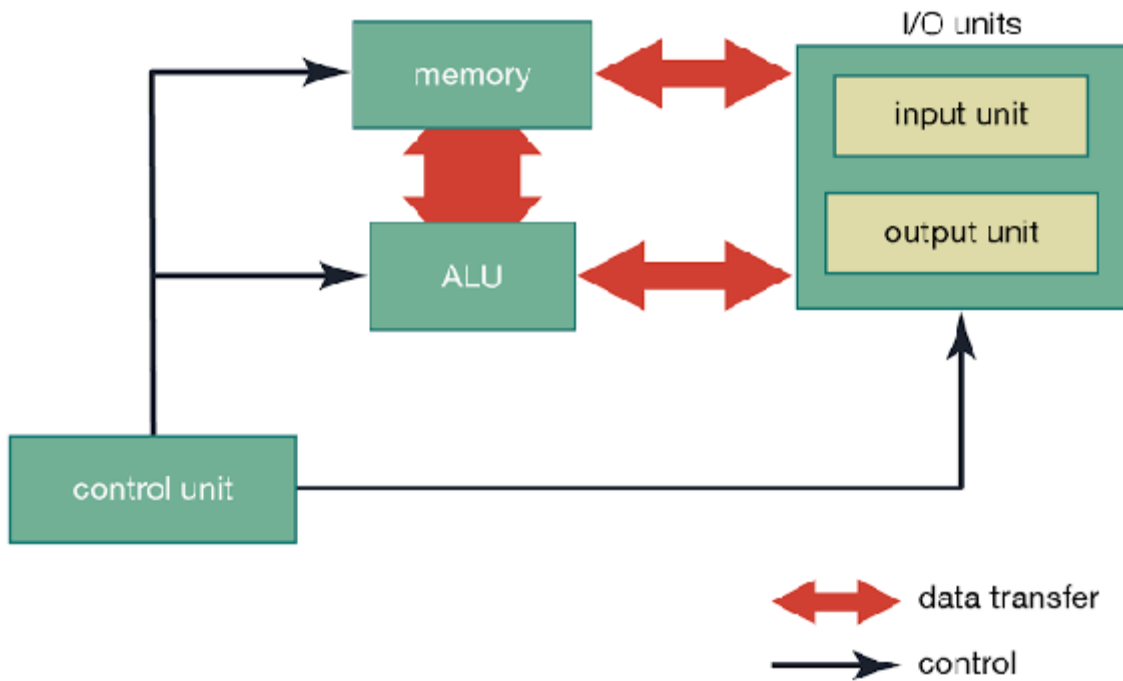

A simplified block diagram of an ALU showing inputs, control signals, and output.

- **Control Unit (CU):** This component manages and coordinates all the activities within the CPU and the rest of the computer system. It fetches instructions from memory, decodes them, and generates control signals to direct other components.

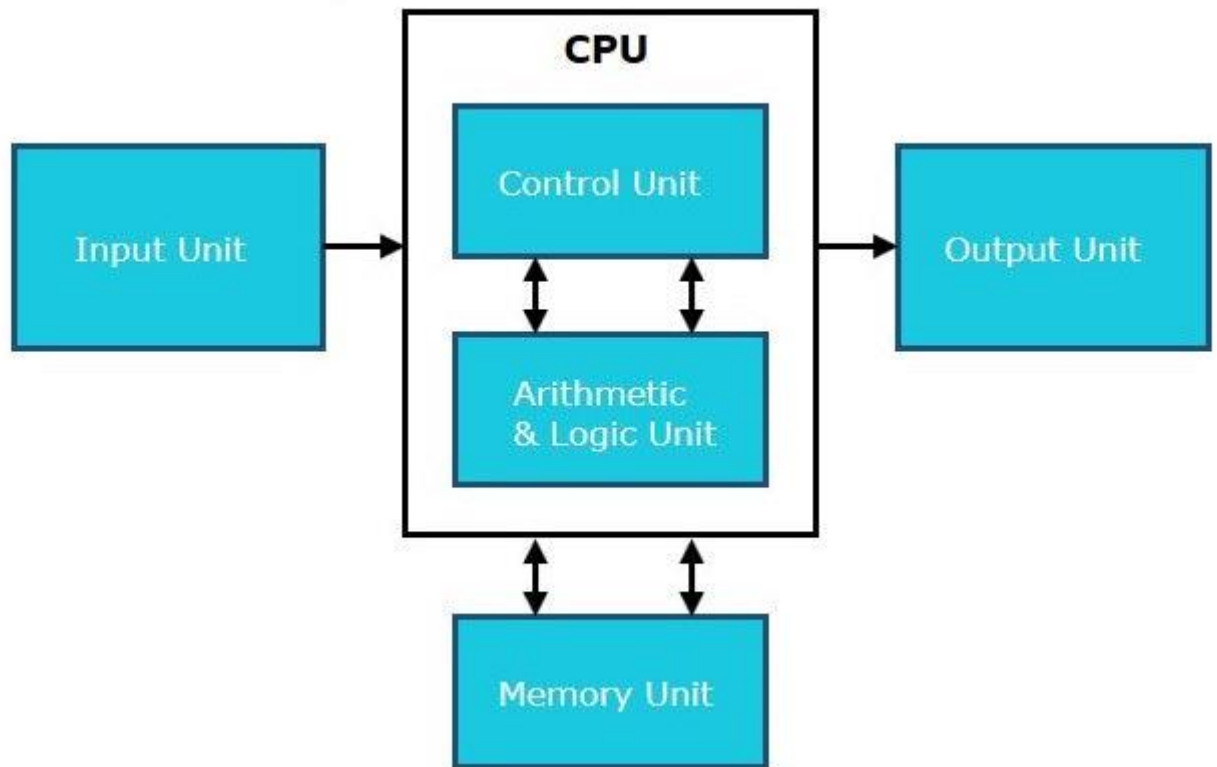

the Control Unit's interaction with memory, ALU, registers, and system buses.

- **Registers:** These are small, high-speed storage locations within the CPU used to temporarily hold data and instructions that are being actively processed. Different types of registers have specific purposes:
 - * **Program Counter (PC):** Holds the address of the next instruction to be executed.
 - **Instruction Register (IR):** Holds the current instruction that is being decoded and executed.
 - **Memory Address Register (MAR):** Holds the address of a memory location to be accessed.
 - **Memory Data Register (MDR):** Holds the data being transferred to or from memory.
 - **Accumulator:** A register used to store intermediate results of calculations.
 - **General-Purpose Registers:** Registers available for general use by the programmer to store operands and results.

CPU Registers

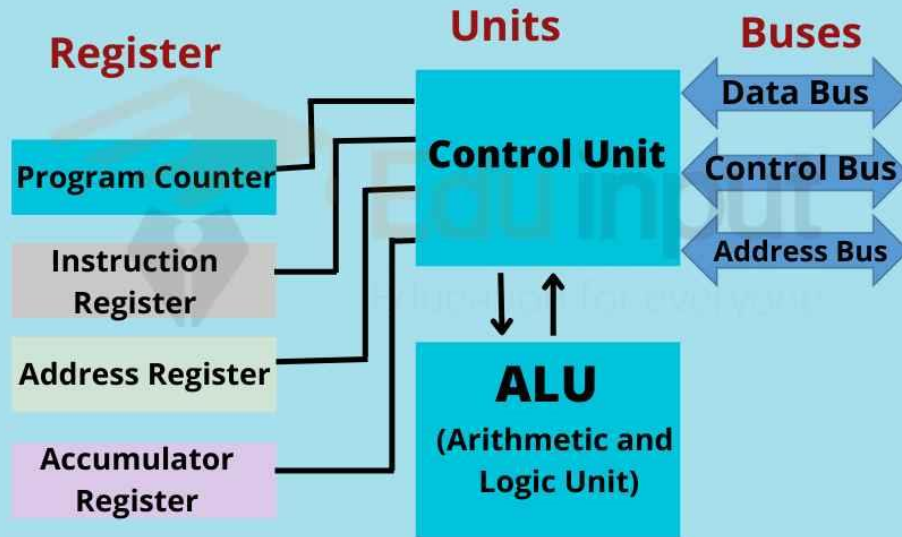

```

+-----+ +-----+ +-----+ +-----+ +-----+ ...
| PC  | |---| | IR  | |---| | MAR | |---| | MDR | |---| | ACC | | ... (Other Registers)
+-----+ +-----+ +-----+ +-----+ +-----+

```

A conceptual diagram showing various registers within the CPU.

- **Buses (Internal Buses):** These are sets of electrical conductors within the CPU that facilitate the transfer of data, addresses, and control signals between the different internal components (ALU, CU, Registers).
 - **Data Bus (Internal):** Carries data between registers and the ALU.
 - **Address Bus (Internal):** Carries addresses of data within the CPU (e.g., register addresses).
 - **Control Bus (Internal):** Carries control signals between the CU and other internal components.

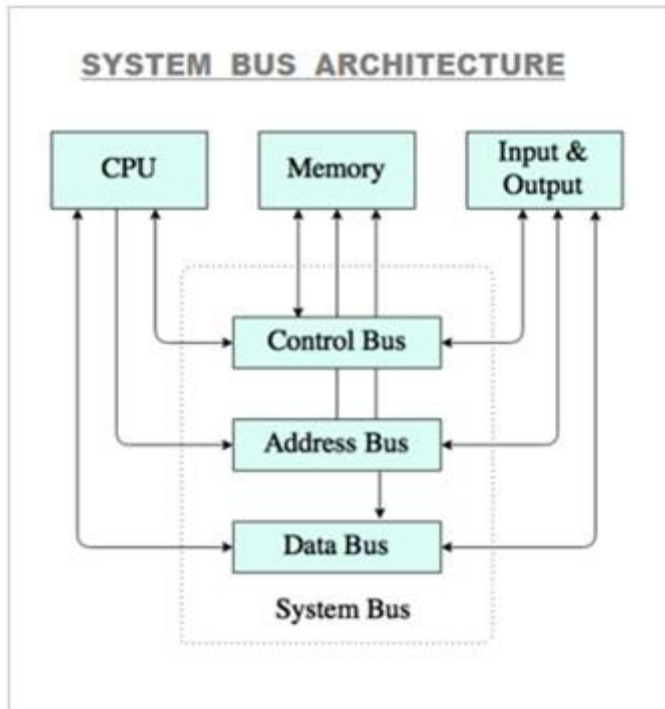

A simplified diagram showing the internal buses connecting the CPU components.

(b) Relate Structural Elements of the CPU to their Functions:

- ❖ **ALU:** Performs the actual computations and logical operations required by the instructions. Without the ALU, the CPU could not process data.
- ❖ **Control Unit:** Acts as the "director" of the CPU and the entire system. It ensures that instructions are fetched in the correct order, decoded properly, and executed by the appropriate components at the right time.
- ❖ **Registers:** Provide fast, temporary storage for data that the CPU needs to access and process quickly. They reduce the need to constantly access slower main memory, significantly speeding up processing.
- ❖ **Internal Buses:** Act as communication pathways within the CPU, allowing the different components to exchange data, addresses, and control signals efficiently.

1.5.2 The Fetch-Decode-Execute Cycle

The CPU executes instructions in a repetitive sequence known as the fetch-decode-execute cycle.

- **Fetch:** The Control Unit retrieves the next instruction from the main memory. The address of this instruction is held in the Program Counter (PC). The instruction is then loaded into the Instruction Register (IR). The PC is incremented to point to the next instruction in sequence.
- **Decode:** The Control Unit interprets the instruction in the IR to determine what operation needs to be performed and what operands (data) are involved.
- **Execute:** The Control Unit sends signals to the ALU and other relevant components to perform the operation specified by the instruction. This may involve arithmetic or logical operations, data transfers between registers and memory, or control flow changes.

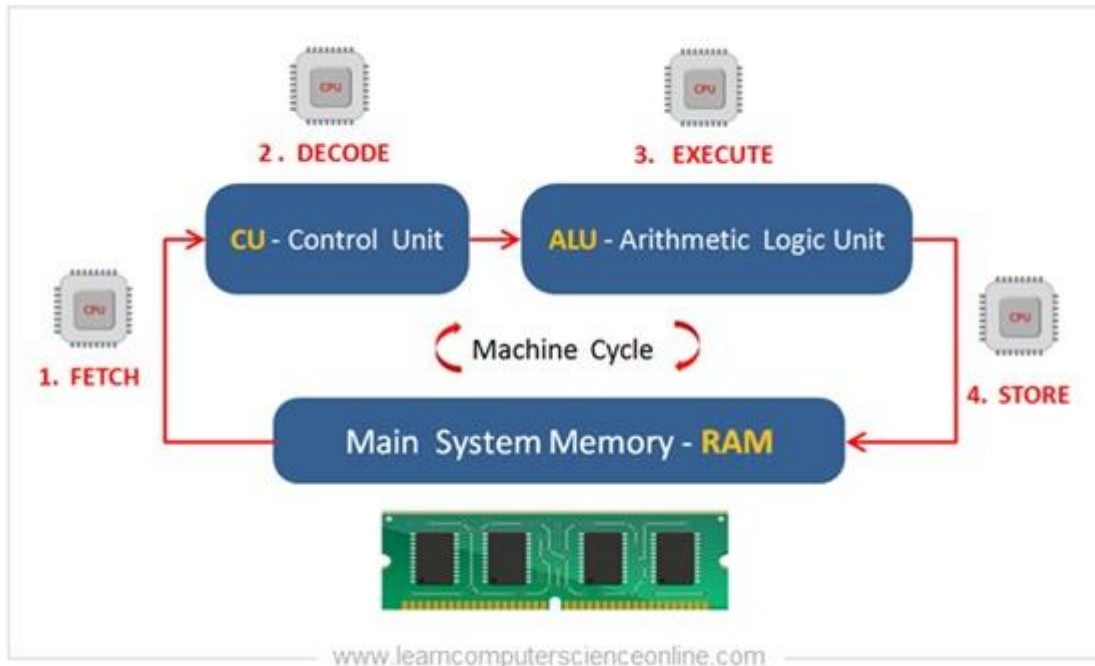

A simplified

flowchart illustrating the Fetch-Decode-Execute cycle.

- **Interaction between CPU, Registers, and Memory during the Cycle:**

1. **Fetch:** The CU uses the address in the PC to fetch the instruction from memory via the system buses and stores it in the IR. The PC is updated.
2. **Decode:** The CU examines the instruction in the IR. If operands are needed from memory, the CU uses the MAR to hold the memory address and the MDR to hold the data being fetched. Registers within the CPU may also be identified as operands.
3. **Execute:** The CU directs the ALU to perform the operation using data from registers and/or the MDR. The result is often stored back in a register or written to memory (using MAR and MDR).

1.5.3 Types of CPUs in Computing Devices

CPUs vary in their architecture and features depending on the intended use and performance requirements of the computing device.

(c) Examine Types of CPUs:

- **Instruction Set Architecture (ISA):** Defines the set of instructions that a CPU can understand and execute.
 - **RISC (Reduced Instruction Set Computer):** Uses a small and simple set of instructions, each typically taking one clock cycle to execute. This can lead to faster overall execution when instructions are pipelined effectively. Examples: ARM (used in most smartphones and tablets), PowerPC.
 - **CISC (Complex Instruction Set Computer):** Uses a large and complex set of instructions, some of which can perform multiple low-level operations. This can make programming easier in some cases but may lead to longer execution times for individual instructions. Example: Intel x86 (used in most desktop and laptop PCs).

- **Word Length:** The number of bits that a CPU can process at one time. Common word lengths are:
 - **16-bit:** Older CPUs that could process 16 bits of data per cycle.
 - **32-bit:** More capable than 16-bit, allowing for larger memory addressing and more complex operations.
 - **64-bit:** Current standard for most desktop and laptop CPUs, offering even greater memory addressing capabilities and performance for demanding tasks.
- **Core Design:** A core is an independent processing unit within a CPU. Modern CPUs often have multiple cores on a single chip (multi-core processors).
 - **Single-Core:** Contains only one processing unit, so it can only execute one instruction at a time.
 - **Multi-Core:** Contains two or more processing units on a single chip, allowing for parallel processing (executing multiple instructions simultaneously), which can significantly improve performance, especially for multitasking and multi-threaded applications.
 - ✓ **Dual-Core:** Two processing cores.
 - ✓ **Quad-Core:** Four processing cores.
 - ✓ **Hexa-Core:** Six processing cores.
 - ✓ **Octa-Core:** Eight processing cores.
 - ✓ **Deca-Core:** Ten processing cores.
 - ✓ CPUs can have even more cores (e.g., in server processors).

(d) Appreciate the Role of the CPU in Computing:

The CPU is the fundamental driving force behind all computing activities. It is responsible for:

- **Executing Instructions:** Running the software programs that allow us to perform tasks on a computer.
- **Performing Calculations:** Handling all the arithmetic and logical operations required by software.
- **Controlling Hardware:** Coordinating the activities of other hardware components through control signals.
- **Managing Data Flow:** Directing the movement of data between memory, input/output devices, and other parts of the system.

Without a functioning CPU, a computer system cannot operate. Its performance directly impacts the speed and responsiveness of the entire system.

1.5.4 Technological Advancements in CPUs

(Key Inquiry Question 1: What are the technological advancements in the development of CPUs?)

The development of CPUs has been marked by continuous and rapid technological advancements:

- **Miniaturization (Moore's Law):** The number of transistors that can be placed on an integrated circuit has roughly doubled every two years, leading to smaller, more powerful, and more energy-efficient CPUs.
- **Increased Clock Speed:** The rate at which the CPU executes instructions (measured in GHz) has steadily increased, leading to faster processing.
- **Multi-Core Architecture:** The introduction of multiple processing cores on a single chip has enabled parallel processing and significantly improved performance for multitasking and multi-threaded applications.

- **Cache Memory:** The integration of high-speed cache memory within the CPU helps to reduce the time it takes to access frequently used data and instructions, improving performance.
- **Improved Instruction Set Architectures:** Innovations in RISC and CISC architectures have led to more efficient instruction execution.
- **Advanced Manufacturing Processes:** Improvements in semiconductor manufacturing techniques allow for the creation of smaller transistors with better performance and lower power consumption.
- **Specialized Processing Units:** Modern CPUs often include specialized units for graphics processing (integrated GPUs), artificial intelligence (AI accelerators), and other specific tasks.
- **Power Efficiency:** Continuous efforts to reduce the power consumption of CPUs are crucial for mobile devices and energy conservation.

1.5.5 CPU Analogy to the Human Brain

(Key Inquiry Question 2: How does the CPU relate to the human brain?)

While the analogy is not perfect, there are some conceptual similarities between the CPU and the human brain:

- **Processing Information:** Both the CPU and the brain process information. The CPU processes digital data and instructions, while the brain processes sensory input, thoughts, and memories.
- **Control Center:** The CPU acts as the central control unit for the computer, directing the activities of other components. Similarly, the brain is the central control unit for the human body, coordinating various functions.
- **Memory:** The CPU uses registers and interacts with main memory to store and retrieve information temporarily. The brain has different types of memory (short-term, long-term) for storing information.
- **"Execution" of Tasks:** The CPU executes instructions to perform tasks. The brain directs the body to perform actions based on thoughts and signals.

However, there are also significant differences:

- **Complexity:** The human brain is vastly more complex and has a far greater capacity for parallel processing and learning than any current CPU.
- **Structure:** The brain has a highly interconnected neural network, while the CPU has a more structured and hierarchical architecture.
- **Functionality:** The brain is capable of consciousness, emotions, creativity, and many other functions that are beyond the capabilities of a CPU.
- **Learning and Adaptation:** The brain can learn and adapt in ways that are still being developed in artificial intelligence for CPUs.

1.5.6 Factors to Consider When Selecting a CPU

When choosing a CPU for a computing device, several factors should be considered based on the intended use and budget:

- **Clock Speed (GHz):** Generally, a higher clock speed means faster processing.
- **Number of Cores:** More cores are beneficial for multitasking and running multi-threaded applications.

- **Cache Size:** A larger cache can improve performance by reducing the time it takes to access frequently used data.
- **Word Length (Bit):** 64-bit CPUs are generally preferred for modern operating systems and applications.
- **Instruction Set Architecture (RISC/CISC):** The choice may depend on the specific software and ecosystem.
- **Integrated Graphics (GPU):** If dedicated graphics are not needed, an integrated GPU can save cost and power.
- **Power Consumption (TDP):** Important for battery life in laptops and heat management in desktops.
- **Socket Compatibility:** The CPU must be compatible with the motherboard socket.
- **Price:** CPUs vary significantly in price depending on their performance and features.
- **Intended Use:** Gaming, video editing, office work, etc., have different CPU requirements.

SUB-STRAND 1.6: OPERATING SYSTEM (OS) (12 Lessons)

An Operating System (OS) is a system software that manages computer hardware and software resources and provides common services for computer programs. It acts as an intermediary between the user and the computer hardware.

(a) Describe Functions of an Operating System:

The OS performs several crucial functions to ensure the smooth operation of a computer system:

- **Booting:** The process of starting up a computer. The OS initiates and manages this process, loading the kernel (the core of the OS) into memory and initializing hardware components.

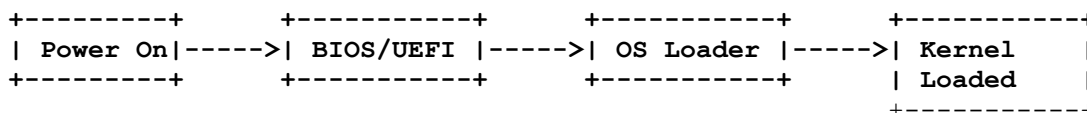
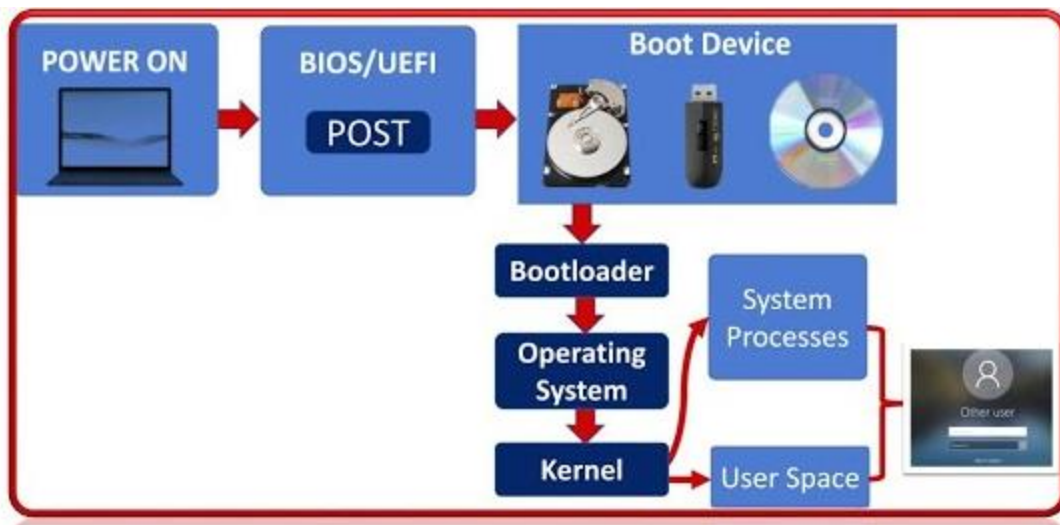

A simplified flowchart of the computer booting process.

- **Resource Management:** The OS manages the computer's resources, including the CPU, memory, input/output devices, and storage, ensuring that they are used efficiently and fairly by different applications.

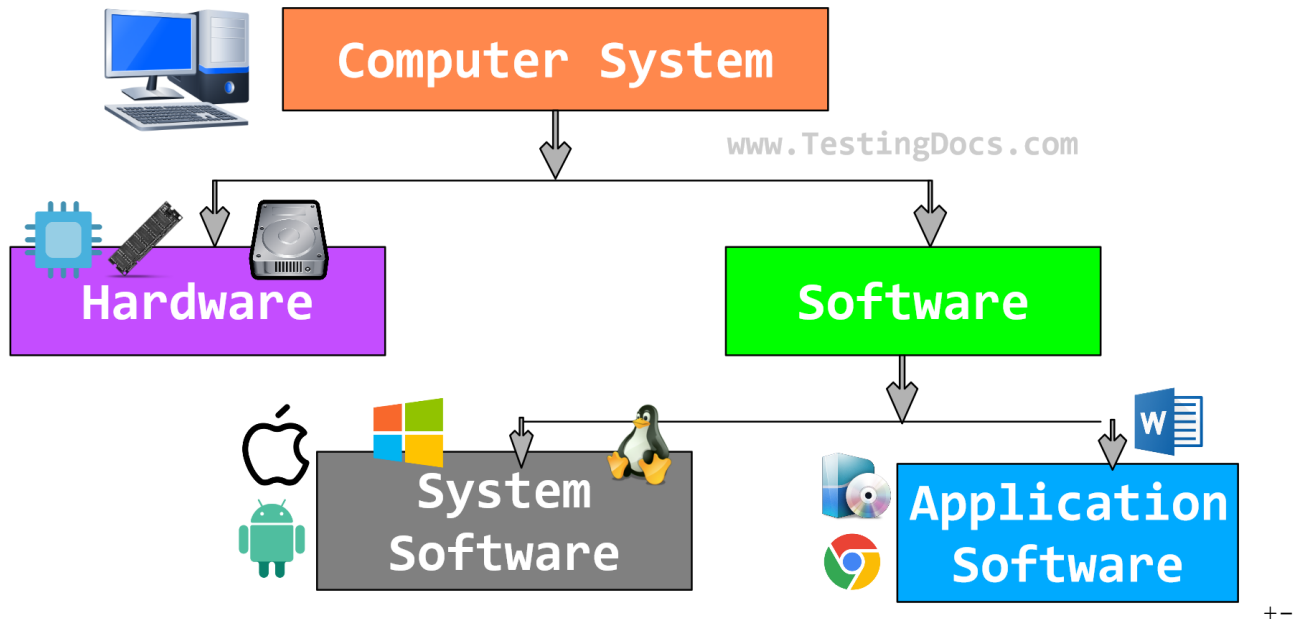

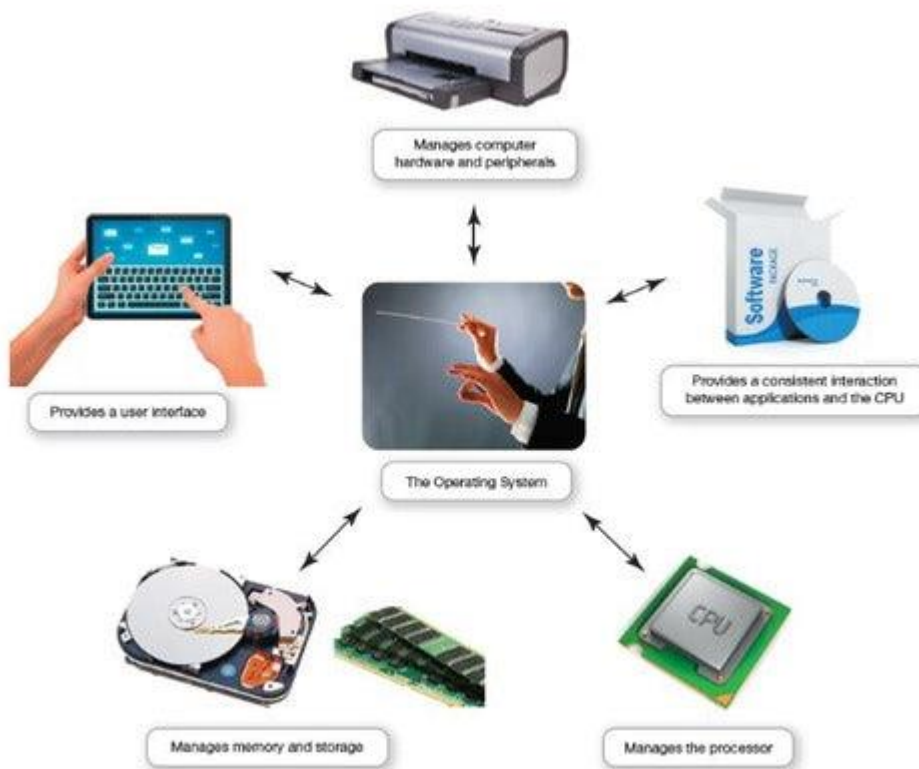

A block diagram showing the OS managing various computer resources.

- **User Interface (UI) or Command Interpreter:** The OS provides a way for users to interact with the computer. This can be through a graphical user interface (GUI) with icons and menus, or a command-line interface (CLI) where users type commands.



A

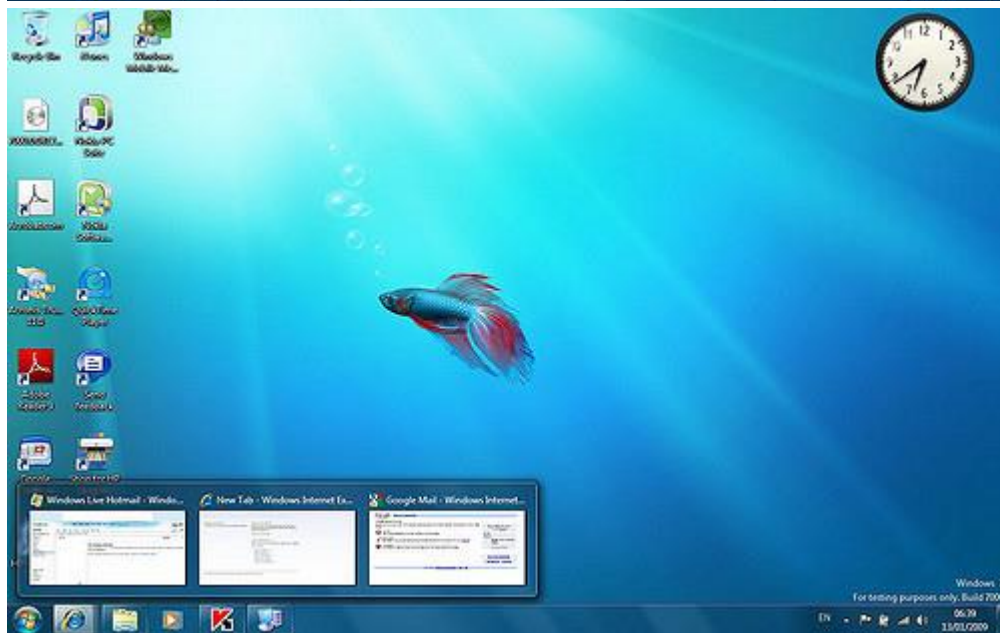

simplified representation of a GUI with icons, menus, and a taskbar.



A screenshot of a command-line interface.

- **Memory Management:** The OS allocates and deallocates memory space for programs, ensuring that different programs do not interfere with each other and that memory is used effectively. This includes techniques like virtual memory.

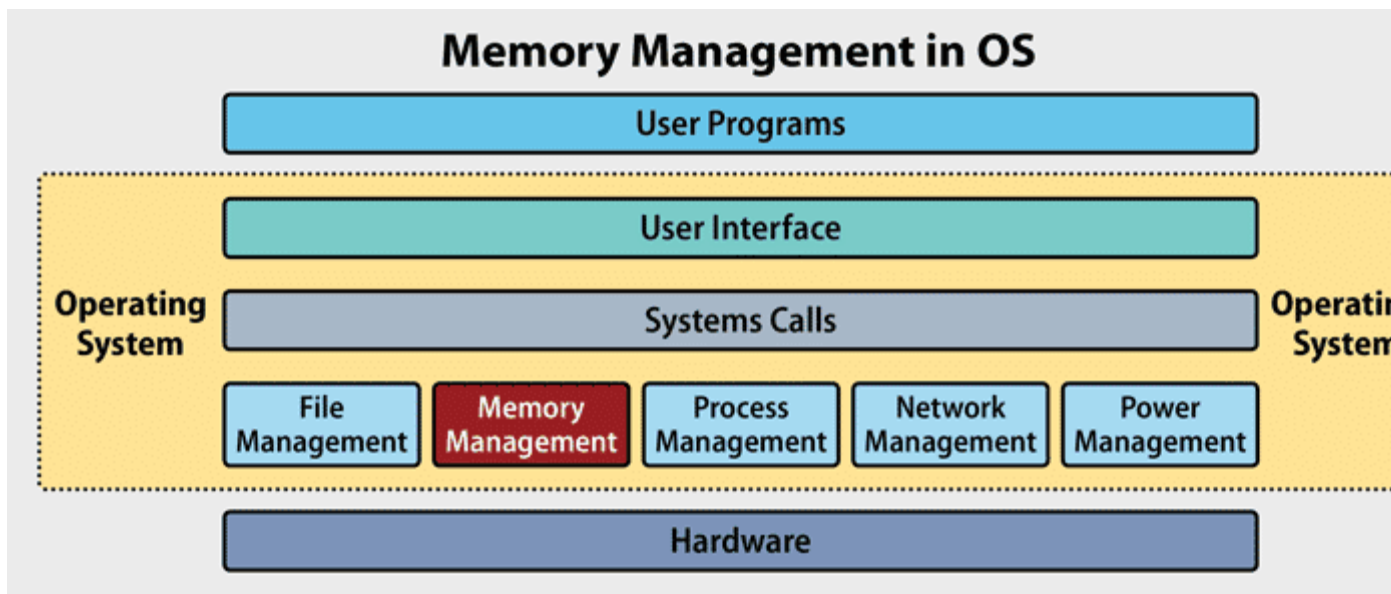

A block diagram illustrating the OS managing memory for different applications.

- **Input/Output (I/O) Management:** The OS controls the communication between the computer and its peripheral devices (input and output devices). It handles requests from applications to use these devices and ensures proper data transfer.

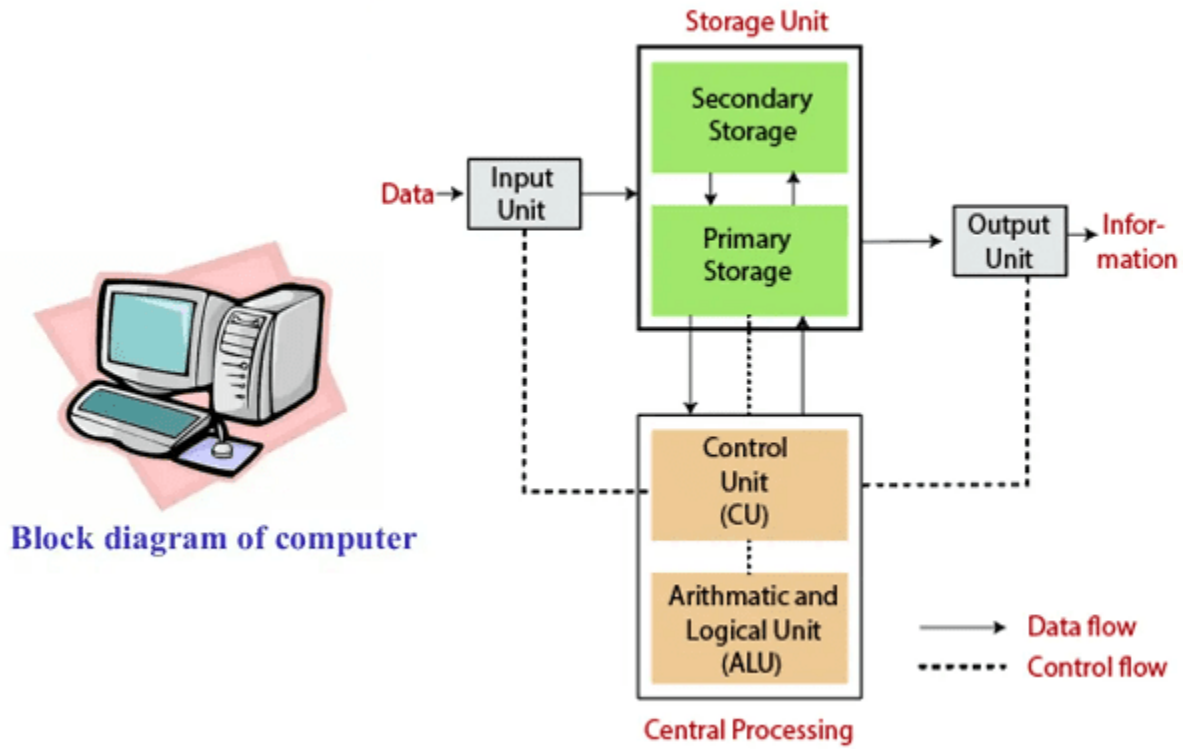

A block diagram showing the OS managing communication with input/output devices.

- **File Management:** The OS organizes and manages files and folders on storage devices. It provides functionalities for creating, deleting, renaming, copying, moving, and securing files. It also maintains the file system structure.



A block diagram illustrating the OS managing files and folders on a storage device.

- **Process Management:** The OS manages the execution of programs (processes). It allocates CPU time and other resources to processes, schedules their execution, and handles process synchronization and communication.

Diagram:

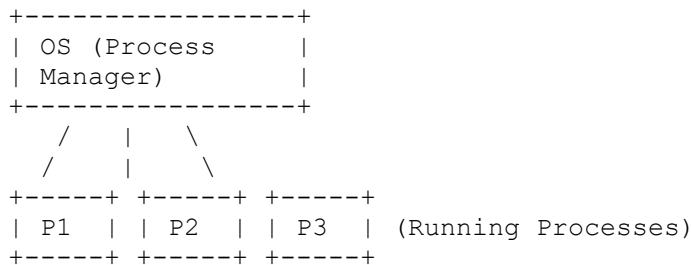

A block diagram showing the OS managing multiple running processes.

- **User Management:** In multi-user systems, the OS manages user accounts, permissions, and security, ensuring that each user has a secure and personalized computing environment.

Diagram:

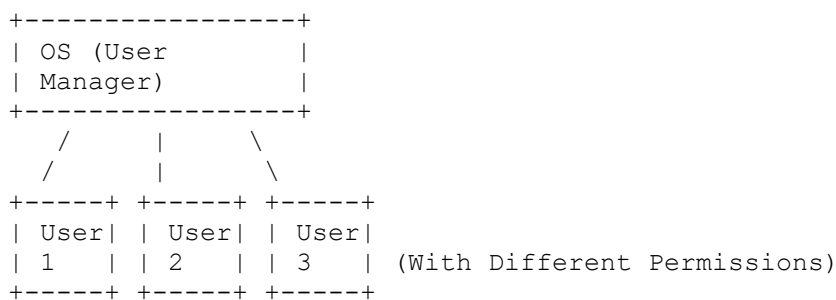

A block diagram illustrating the OS managing multiple users with different access levels.

1.6.2 Classification of Operating Systems

(b) Classify Operating Systems According to Different Attributes:

Operating systems can be classified based on several characteristics:

- **According to Tasks:**
 - ✓ **Single-tasking OS:** Allows only one program to run at a time. Examples: Older mobile phone OS, some embedded systems.

Image:

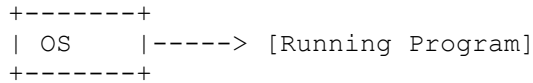

A simple diagram showing the OS running one program at a time.

Multi-tasking OS: Allows multiple programs to run concurrently. The OS rapidly switches between programs, giving the illusion of simultaneous execution. Most modern OS are multi-tasking. Examples: Windows, macOS, Linux, Android, iOS.

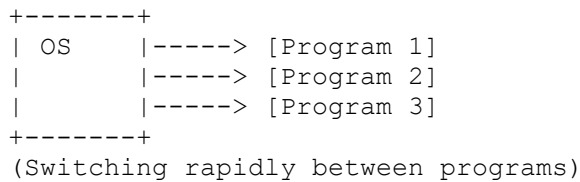

A diagram showing the OS managing multiple programs concurrently.

- **According to Users:**

- ✓ **Single-user OS:** Designed for use by a single user at a time. Examples: DOS, older versions of Windows (e.g., Windows 98), macOS (primarily single-user, though supports fast user switching).

Image:

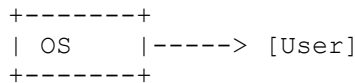

A simple diagram showing one user interacting with the OS.

- ✓ **Multi-user OS:** Allows multiple users to access the computer system simultaneously, often through terminals connected to a central server. Examples: UNIX, Linux (server versions), Windows Server.

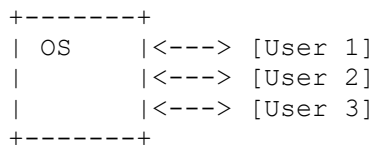

A diagram showing multiple users interacting with the OS simultaneously.

- **According to User Interface:**

- ✓ **Graphical User Interface (GUI):** Uses visual elements like icons, menus, and windows for user interaction. Easier to learn and use for most people. Examples: Windows, macOS, Ubuntu (with GNOME or KDE), Android, iOS.

- **Image:** (Refer to the GUI image in function description)
- ✓ **Command Line Interface (CLI):** Requires users to type text-based commands to interact with the OS. More powerful and efficient for certain tasks but has a steeper learning curve. Examples: Command Prompt (Windows), Terminal (macOS, Linux).
 - **Image:** (Refer to the CLI image in function description)
- ✓ **Menu-Driven Interface:** Presents users with a series of menus to navigate and select options. Common in embedded systems and some older applications.



A simplified representation of a menu-driven interface.

1.6.3 Installing and Using an Operating System

(c) Install an Operating System in a Computer:

Installing an OS typically involves the following general steps:

1. Preparation:

- ✓ Ensure the computer meets the minimum hardware requirements for the OS.

- ✓ Obtain the OS installation media (USB drive, DVD, or network installation files).
 - ✓ Back up any important data on the computer's storage.
 - ✓ Configure the computer's BIOS/UEFI settings to boot from the installation media.
2. **Boot from Installation Media:** Restart the computer and boot from the USB drive or DVD.
 3. **Start the Installation Process:** The OS installer will start, prompting you to begin the installation.
 4. **Language and Regional Settings:** Select your preferred language, keyboard layout, and time zone.
 5. **Installation Type:** Choose between a clean install (erasing existing data) or an upgrade (keeping existing files, if supported).
 6. **Disk Partitioning:** Configure the hard drive or SSD by creating, deleting, or resizing partitions where the OS will be installed.
 7. **File Copying and Installation:** The installer will copy the OS files to the selected partition and install the necessary components.
 8. **Configuration:** Set up user accounts, computer name, network settings, and other initial configurations.
 9. **Driver Installation:** The OS may automatically install drivers for hardware components. Additional drivers may need to be installed manually.
 10. **Restart:** The computer will typically restart to complete the installation process.

(d) Use an Operating System to Perform a Task:

Operating systems provide tools and interfaces to perform various tasks, such as:

- **File and Folder Management:**
 - ✓ **Create:** Right-click in a folder and select "New" -> "Folder" or "File Type".
 - ✓ **Rename:** Right-click on a file or folder and select "Rename", then type the new name.
 - ✓ **Delete:** Right-click on a file or folder and select "Delete" (often moves to the Recycle Bin/Trash).
 - ✓ **Restore:** Open the Recycle Bin/Trash, right-click on the deleted item, and select "Restore".
 - ✓ **Copy:** Right-click on a file or folder, select "Copy", then right-click in the destination folder and select "Paste". Alternatively, use keyboard shortcuts (Ctrl+C/Cmd+C and Ctrl+V/Cmd+V).
 - ✓ **Move:** Right-click on a file or folder, select "Cut", then right-click in the destination folder and select "Paste". Alternatively, drag and drop the item to the new location.
 - ✓ **Backup:** Copy important files and folders to an external storage device or cloud storage. Some OS have built-in backup utilities.
- **Error Handling:** The OS detects and handles errors such as program crashes, hardware malfunctions, and file access issues. It may display error messages or attempt to recover from the error.
- **Managing Input/Output Devices:** The OS allows applications to use input devices (keyboard, mouse) to interact with the system and sends output to output devices (monitor, printer).
- **Managing Storage Devices:** The OS organizes files on storage devices, manages free space, and ensures data integrity.

1.6.4 Importance of Operating Systems in Computing

(e) Acknowledge the Importance of Operating Systems in Computing:

Operating systems are fundamental to modern computing. They are essential because they:

- ✓ **Provide a User Interface:** Make computers accessible and usable for individuals without deep technical knowledge.
- ✓ **Manage Hardware Resources:** Allow multiple applications to share the computer's resources efficiently and prevent conflicts.
- ✓ **Enable Multitasking:** Allow users to run multiple applications simultaneously, improving productivity.
- ✓ **Provide a Platform for Applications:** Create a consistent environment for software developers to write applications that can run on different hardware configurations.
- ✓ **Handle System Security:** Implement security features to protect the computer and its data from unauthorized access and malware.
- ✓ **Ensure Stability and Reliability:** Manage system processes and resources to prevent crashes and ensure smooth operation.
- ✓ **Facilitate File Management:** Organize and provide easy access to data stored on the computer.

Without an operating system, a computer would be a collection of isolated hardware components that users could not easily interact with or utilize effectively. The OS is the crucial layer of software that makes the hardware useful and enables the execution of all other software applications.

1.6.5 How an Operating System Communicates with Computer Hardware

(Key Inquiry Question: How does an operating system communicate with computer hardware?)

The operating system communicates with computer hardware through a layered approach involving **device drivers** and **system calls**:

1. **Device Drivers:** These are software programs that act as translators between the OS and specific hardware devices. Each type of hardware (e.g., a particular model of printer, graphics card, or network adapter) requires a specific device driver.

When an application wants to use a hardware device, it communicates with the OS.

The OS then uses the appropriate device driver to send commands and receive data from the hardware.

The driver understands the specific language and protocols of the hardware device.

Diagram:

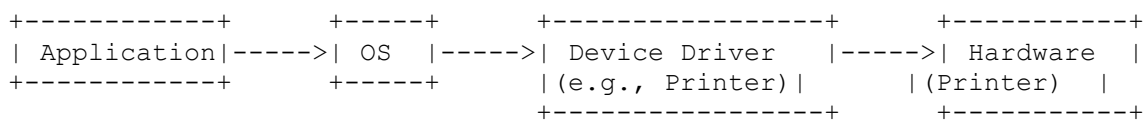

A block diagram showing an application communicating with hardware through the OS and a device driver.

2. **System Calls:** These are programmatic ways in which a user-level program can request services from the kernel of the operating system. Hardware-related operations (like accessing a file on disk, sending data to a printer, or receiving input from a keyboard) are typically privileged operations that user programs cannot

perform directly. Instead, they make system calls to the OS kernel, which then interacts with the hardware on their behalf using device drivers.

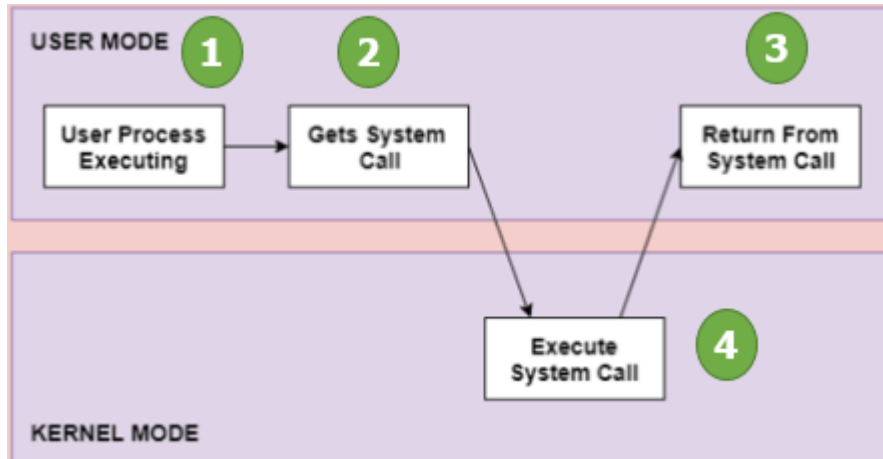

A block diagram showing an application making a system call to the OS, which then uses a device driver to interact with hardware.

SUB-STRAND 1.7: COMPUTER SETUP

1.7.1 Computer Ports and Cables

Ports are connection points on a computer where external devices (peripherals) can be plugged in using cables. Cables are physical wires or optical fibers that transmit data, power, or signals between the computer and these devices.

(a) Explain Types of Ports and Cables:

Here are some common types of ports and their corresponding cables found on computer systems:

- **USB (Universal Serial Bus):** A versatile port used for connecting a wide range of peripherals like keyboards, mice, printers, external hard drives, flash drives, digital cameras, and smartphones. USB ports come in different standards (USB 2.0, USB 3.0, USB-C) with varying data transfer speeds and connector types (Type-A, Type-B, Mini-B, Micro-B, Type-C).
 - **Port Image (USB Type-A):**



A picture of a USB Type-A port.

- **Cable Image (USB Type-A to Type-B):**



A picture of a USB Type-A to Type-B cable.

- **Cable Image (USB Type-A to Micro-B):**



A picture of a USB Type-A to Micro-B cable.

○ **Port Image (USB Type-C):**



A picture of a USB Type-C port.

○ **Cable Image (USB Type-C to Type-C):**



A picture of a USB Type-C to Type-C cable.



A picture of a USB Types-A,B C cables.

- **HDMI (High-Definition Multimedia Interface):** Used for transmitting high-definition video and audio signals from a computer to a monitor, TV, or projector.



A picture of an HDMI port.

- **Cable**



A picture of an HDMI cable.

- **DisplayPort (DP):** Another interface for transmitting high-resolution video and audio, often used as an alternative to HDMI, especially in computer monitors and some high-end graphics cards.



A picture of a Display cable



Dp port

- **VGA (Video Graphics Array):** An older analog interface used to connect monitors to computers. It transmits only video signals. Often colored blue.



A picture of a VGA port.

o **Cable Image:**



A picture of a VGA cable.

- **DVI (Digital Visual Interface):** A digital interface used to connect monitors to computers. It can transmit both analog and digital video signals depending on the type (DVI-A, DVI-D, DVI-I).

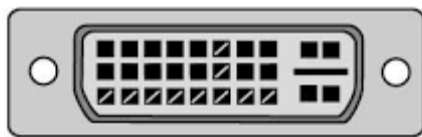

Dual Link DVI-I



Dual Link DVI-D

© 2003 HowStuffWorks

A picture of a DVI-I port.

○ **Cable Image:**



A picture of a DVI cable.

- **Ethernet (RJ-45):** Used for connecting computers to a network (LAN) or the internet via a wired connection.



○

A picture of an Ethernet port (RJ-45).

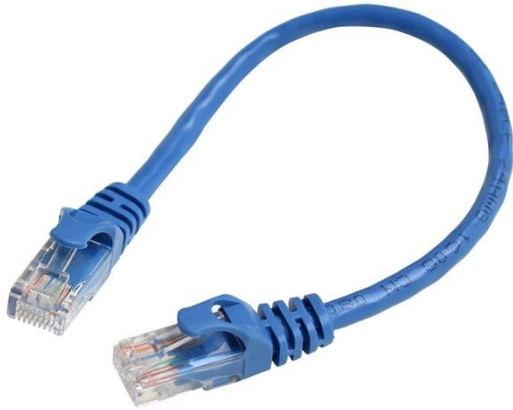

A picture of an Ethernet cable (RJ-45).

- **Audio Ports (3.5mm Jack):** Typically used for connecting headphones, speakers, and microphones. Often color-coded (green for audio out, pink for microphone in, blue for line in).
 - **Port Image (Audio Out - Green):**



A picture of a 3.5mm audio output port (often green).



A picture of a 3.5mm audio cable.

- **Power Connector:** Used to connect the computer to a power outlet. The type of connector varies depending on the power supply unit.
 - **Port Image (Power Input - IEC C14):**



A picture of an IEC C14 power input port on a computer power supply.



A picture of a typical computer power cable.

(b) Relate Cables to their Corresponding Ports:

It is crucial to match the correct cable connector to its corresponding port on the computer and peripheral devices. Forcing a cable into the wrong port can damage both the cable and the port. Key matching points include:

- **Shape and Size:** The shape and number of pins or contacts on the cable connector must align perfectly with the port.
- **Orientation:** Some connectors, like USB Type-A, have a specific orientation. Others, like USB-C and HDMI, are reversible.
- **Color Coding:** While not always a primary indicator, color coding can sometimes help identify audio or older video ports (e.g., blue for VGA, green for audio out).
- **Labels or Symbols:** Look for labels or symbols near the ports that indicate their function (e.g., "HDMI," "USB," "LAN").

1.7.2 Setting Up a Computer for Use

(c) Set up a Computer for Use:

Setting up a computer involves connecting all the necessary peripherals and ensuring proper power and network connections. Here is a general procedure:

1. **Unpacking:** Carefully unpack all the components, including the computer case (system unit), monitor, keyboard, mouse, power cables, and any other peripherals. Keep the manuals and driver disks.
2. **Placement:** Position the computer case and monitor in a well-ventilated and stable location. Ensure there is enough space for cables and airflow.
3. **Connecting the Monitor:**
 - Connect one end of the appropriate video cable (HDMI, DisplayPort, DVI, or VGA) to the video output port on the back of the computer case. This port is usually located on the graphics card or the motherboard.
 - Connect the other end of the video cable to the video input port on the monitor.
 - Connect the monitor's power cable to a power outlet and to the monitor itself.
4. **Connecting the Keyboard and Mouse:**
 - Connect the keyboard and mouse cables to the USB ports on the back or front of the computer case. USB ports are usually rectangular.
 - Some keyboards and mice may be wireless, requiring a USB receiver to be plugged into a USB port. Ensure batteries are installed if needed.
5. **Connecting Speakers or Headphones (Optional):**
 - If using wired speakers or headphones, connect the audio cable (usually a 3.5mm jack) to the audio output port (usually green) on the back or front of the computer case.
 - If using USB speakers or wireless audio devices, connect them via USB or follow the manufacturer's instructions for pairing.
6. **Connecting Network Cable (Optional):**
 - If using a wired network connection, connect one end of an Ethernet cable (RJ-45) to the Ethernet port on the back of the computer case and the other end to a network port on a router or modem.
7. **Connecting Power to the Computer Case:**
 - Connect one end of the computer's power cable to the power input port on the back of the computer case.
 - Connect the other end of the power cable to a grounded power outlet. It is recommended to use a surge protector to protect the computer from power surges.
8. **Turning on the Computer and Monitor:**
 - Press the power button on the computer case.
 - Press the power button on the monitor.
9. **Initial Setup (Operating System):**
 - If it's a new computer or a freshly installed operating system, follow the on-screen prompts to configure the OS (language, region, user accounts, network settings, etc.).
10. **Installing Drivers (If Necessary):**
 - The OS usually installs basic drivers automatically. However, you may need to install specific drivers for certain hardware components (e.g., graphics card, printer) using the provided driver disks or by downloading them from the manufacturer's website.
11. **Installing Software:**
 - Once the OS is set up, you can install the applications and software you need.

(d) Appreciate Following the Correct Procedure:

Following the correct procedure when setting up a computer is important for several reasons:

- **Safety:** Incorrect connections or handling can lead to electrical hazards or damage to the equipment.
- **Preventing Damage:** Forcing cables into the wrong ports can damage the pins or connectors.
- **Ensuring Proper Functionality:** Connecting peripherals to the correct ports ensures they will work as intended.
- **Organized Setup:** Following a logical order makes the setup process smoother and reduces the chance of missing a step.
- **Troubleshooting:** If issues arise, a systematic setup makes it easier to identify the source of the problem.

STRAND 2: COMPUTER NETWORKING

SUB-STRAND 2.1: DATA COMMUNICATION

2.1.1 Basic Data Communication Concepts

Data communication refers to the process of transferring data or information between two or more digital devices over a communication medium.

(a) Define Basic Data Communication Concepts:

- **Data:** Raw, unprocessed facts, figures, symbols, or signals that represent information. In computing, data is often represented digitally (as bits).

```
+---+---+---+---+---+
| 0 | 1 | 0 | 0 | 1 | ... (Bits of Data)
+---+---+---+---+---+
```

A representation of binary data (bits).

- **Signals:** The electrical or electromagnetic impulses used to transmit data over a communication channel. Signals can be analog or digital.
 - **Analog Signals:** Continuous wave signals that vary in amplitude, frequency, or phase to represent data.

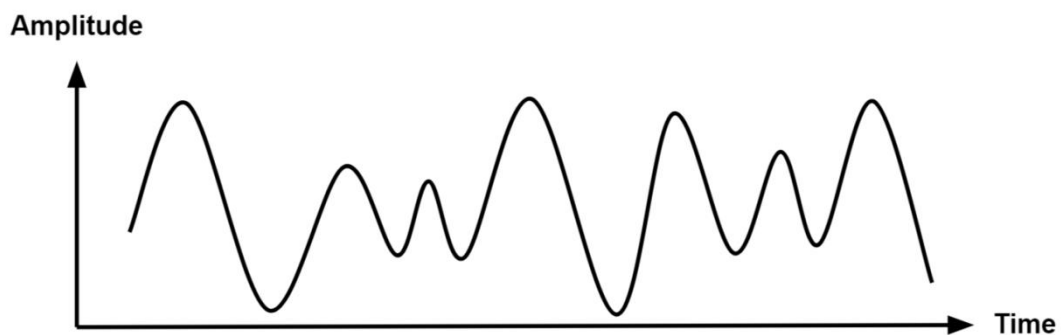

A graph showing a continuous analog signal varying in amplitude over time.

- **Digital Signals:** Discrete signals that have a finite number of distinct levels (usually two: high and low, represented as 1 and 0).

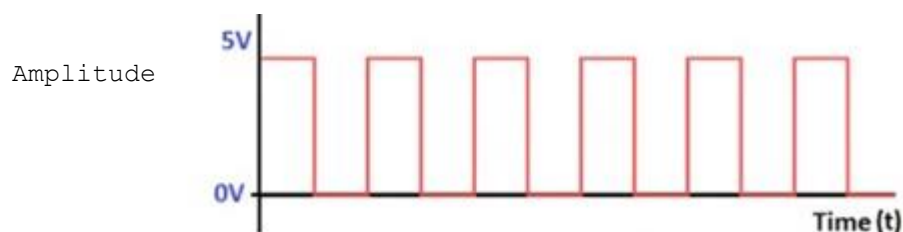

1 0 1 1 0 1 0 1 1 0

A graph showing a discrete digital signal with high (1) and low (0) levels over time.

- **Communication Channel (Medium):** The physical pathway or means through which data signals are transmitted from a sender to a receiver. Examples include copper wires, fiber optic cables, radio waves, microwaves, and infrared.



A picture of a copper wire used as a communication channel.



A cross-section of a fiber optic cable transmitting light pulses.

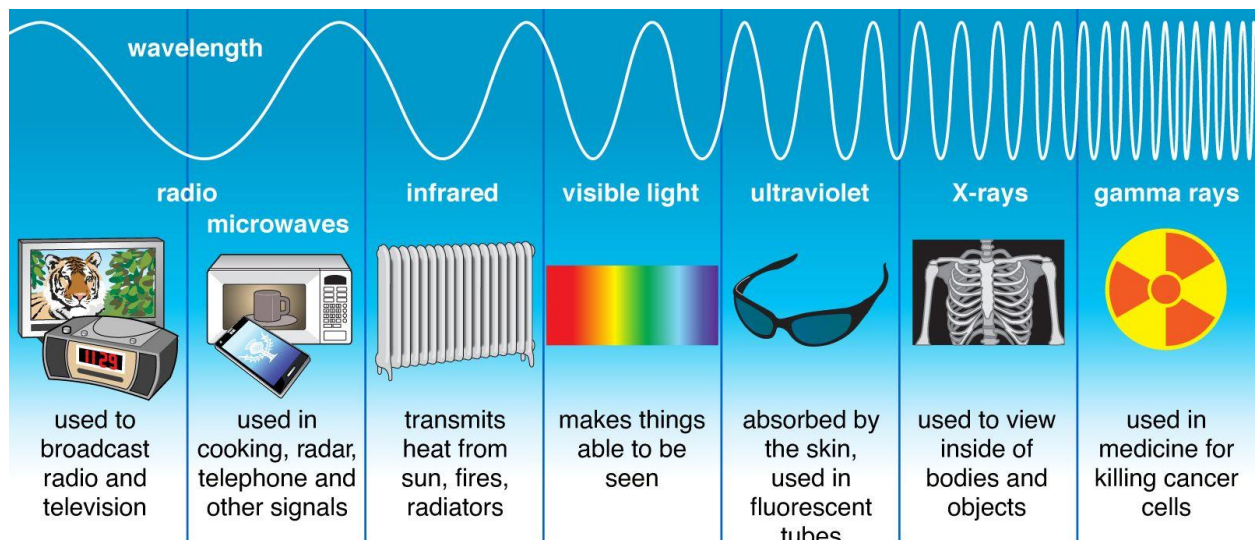
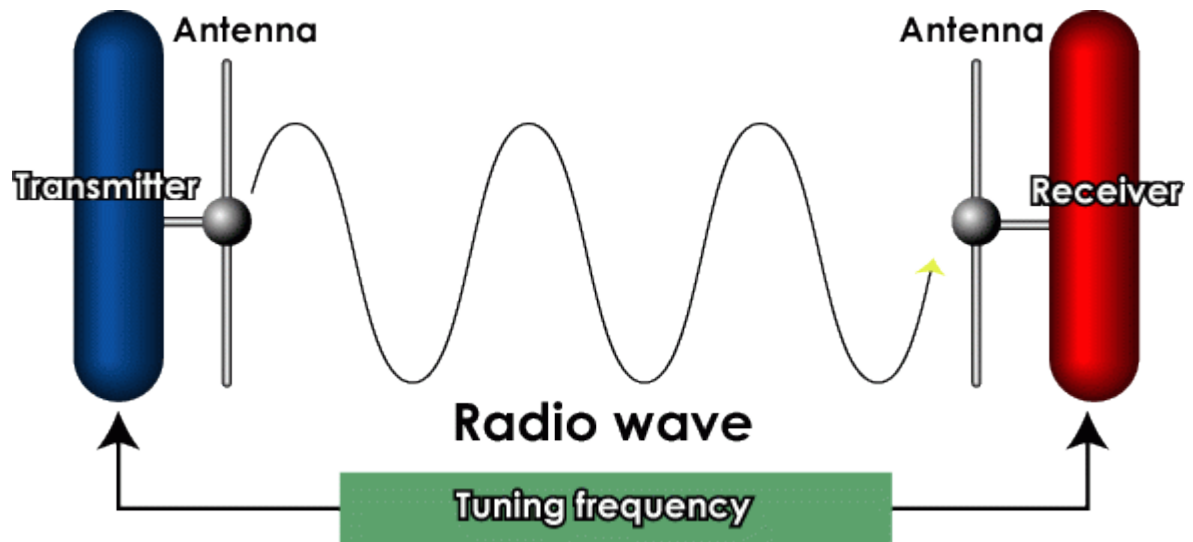

© Encyclopædia Britannica, Inc.

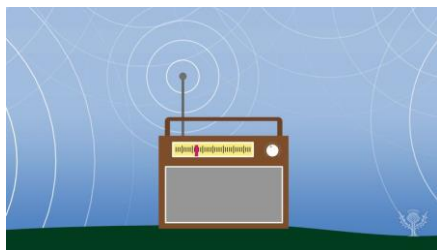

conceptual representation of radio waves propagating through the air.

- **Network:** A collection of interconnected devices (computers, servers, routers, etc.) that can communicate and share resources. Data communication is the fundamental process that enables networking.
 - **Diagram:**

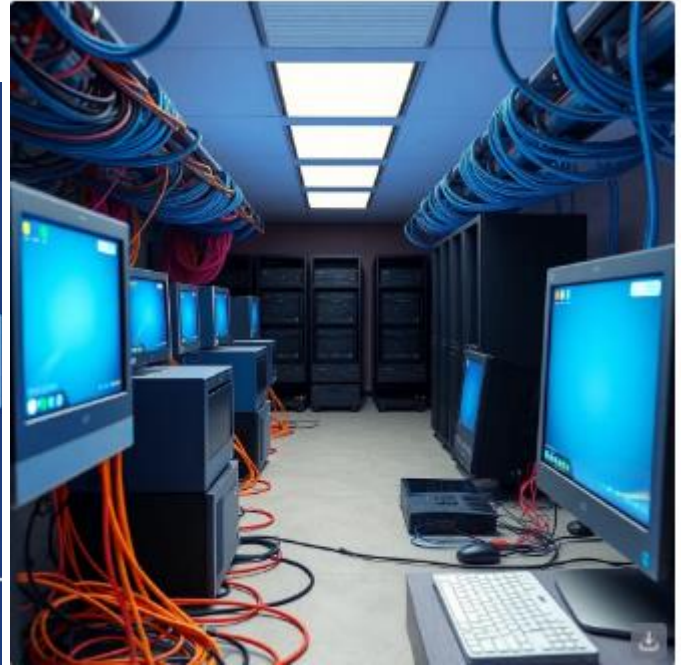

A basic diagram of a computer network showing interconnected devices.

- **Transmission Media:** The physical substance or electromagnetic waves used to carry data signals. This is closely related to the communication channel. Can be guided (wired) or unguided (wireless).
 - **Guided Media:** Physical cables like twisted pair, coaxial cable, and fiber optic cable.
 - **Unguided Media:** Wireless transmission through air or space using radio waves, microwaves, infrared, and light.
- **TCP/IP (Transmission Control Protocol/Internet Protocol):** A suite of communication protocols used to interconnect network devices on the internet. TCP provides reliable, ordered, and error-checked delivery of data, while IP handles addressing and routing of data packets.
 - **Diagram:**
 - +-----+ +-----+ +-----+ +-----+
 - | Application| (Data) | TCP | (Segments) | IP | (Packets) | Network |
 - +-----+----->+----->+----->+----->+-----+

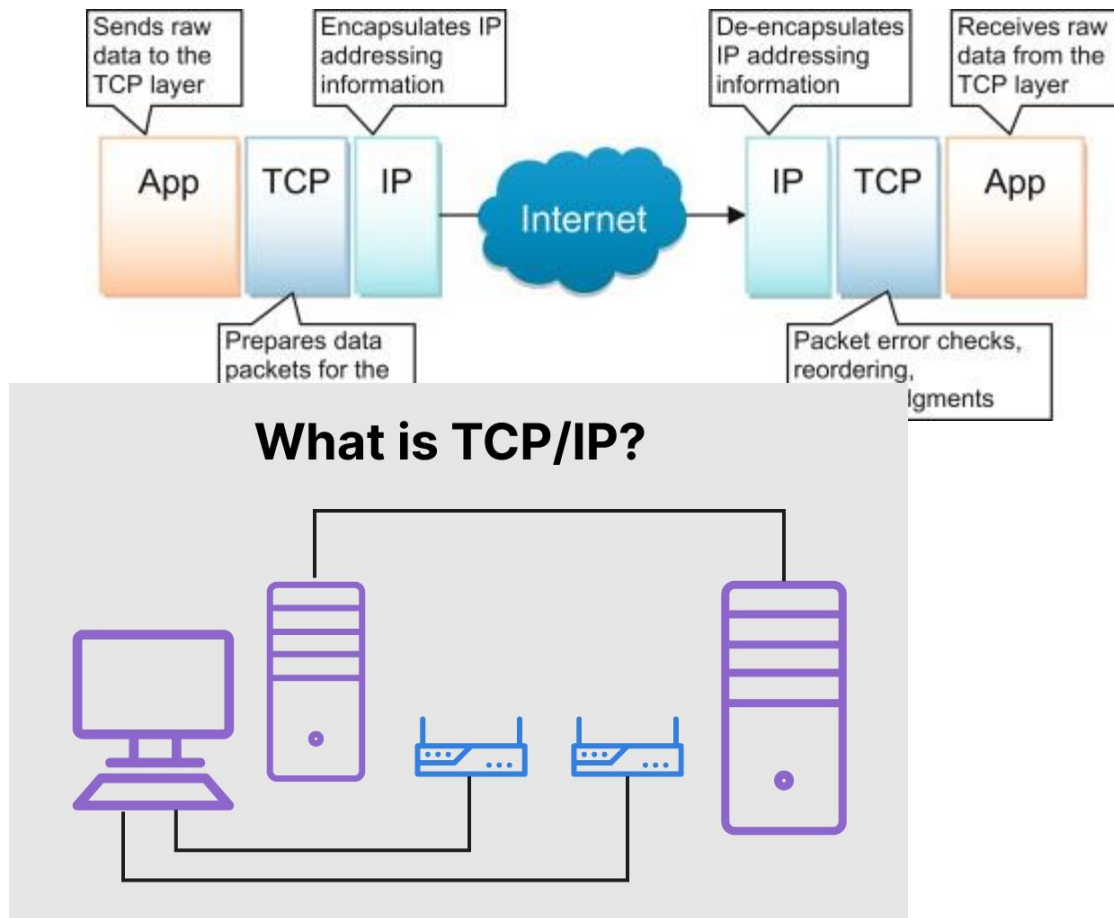

A simplified diagram showing how data is encapsulated with TCP and IP headers.

- **OSI (Open Systems Interconnection) Model:** A conceptual framework that standardizes the functions of a telecommunication or computing system in terms of abstraction layers. It has seven layers: Physical, Data Link, Network, Transport, Session, Presentation, and Application. It provides a reference for understanding how data communication occurs.
 - **Diagram:**

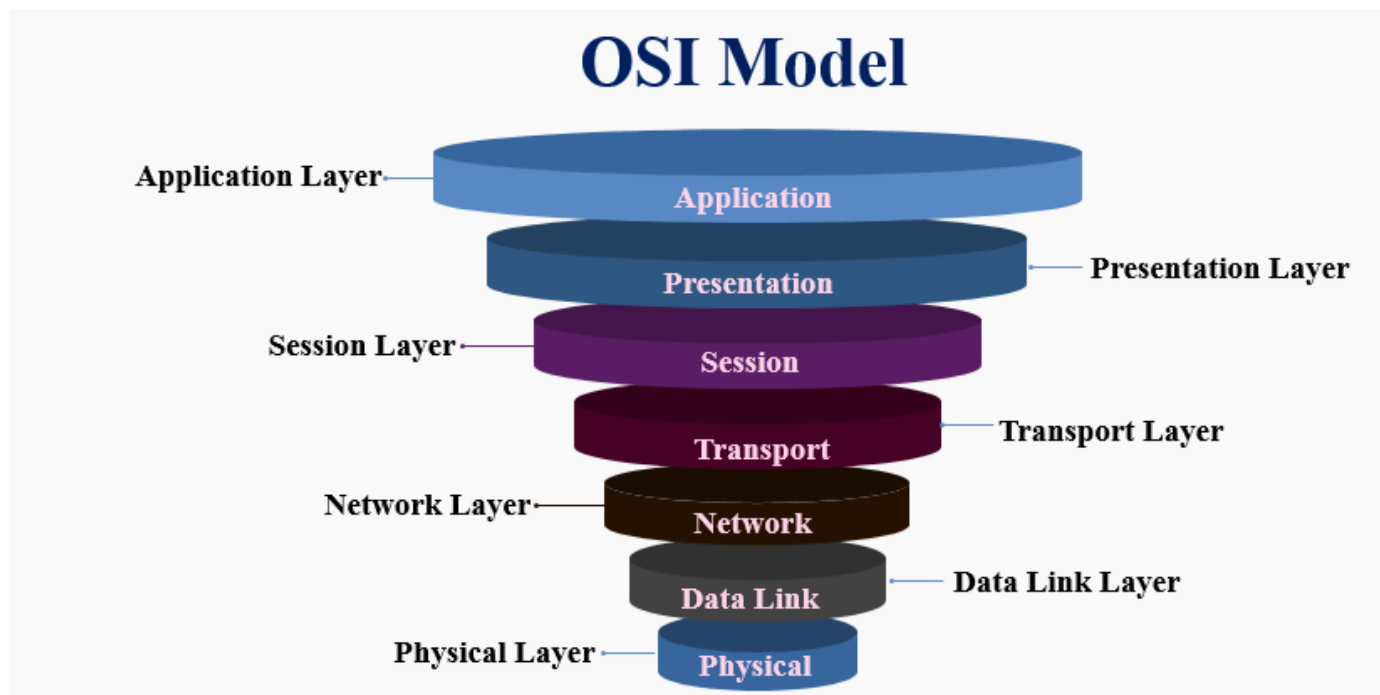

A diagram listing the seven layers of the OSI model.

- **Protocols:** A set of rules and procedures that govern how data is transmitted and received over a communication channel. Protocols ensure that communicating devices can understand each other. Examples include TCP/IP, HTTP, FTP, SMTP.

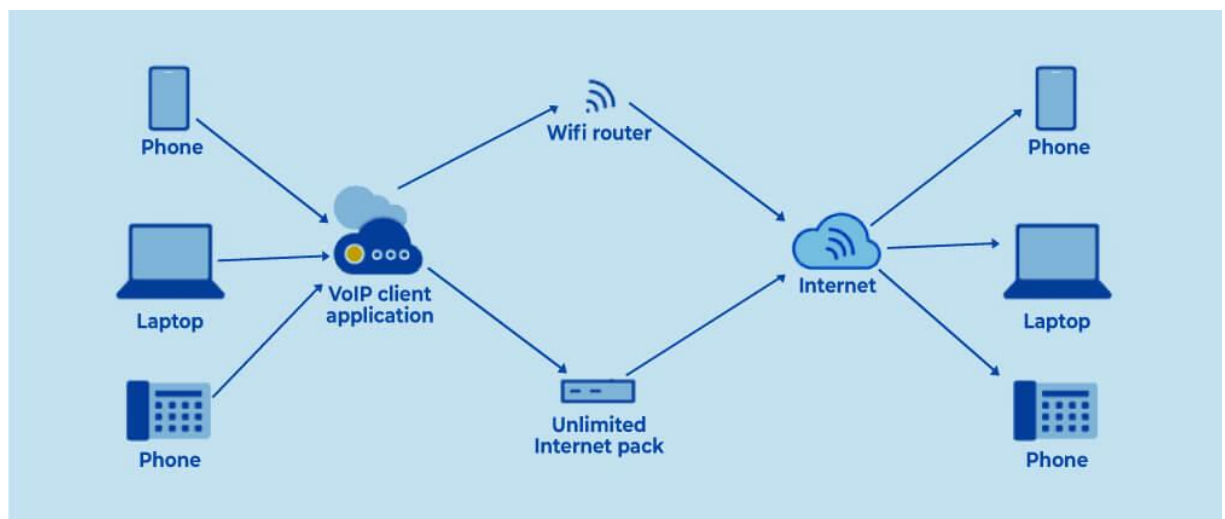

A conceptual image showing two devices communicating using a common protocol.

- **Data Rate (Bit Rate):** The number of bits of data transmitted per unit of time, usually measured in bits per second (bps), kilobits per second (kbps), megabits per second (Mbps), or gigabits per second (Gbps).
- **Baud Rate:** The number of signal units (symbols) transmitted per unit of time. In some cases, one baud corresponds to one bit, but in more complex modulation schemes, one baud can represent multiple bits.

- **Bandwidth:** The range of frequencies available for data transmission in a communication channel. A wider bandwidth allows for higher data rates. Often used informally to refer to the data rate capacity of a network connection.

2.1.2 Characteristics of Data Communication

(b) Describe Characteristics of Data Communication:

Effective data communication systems exhibit several key characteristics:

- **Delivery:** The system must deliver data to the correct destination accurately.
- **Accuracy:** The transmitted data should be exactly as it was sent, without errors. Error detection and correction mechanisms are often employed.
- **Timeliness:** Data should be delivered within an acceptable time frame. For real-time applications (like video conferencing), delays can make the communication unusable.
- **Jitter:** Refers to the variation in the delay of data packets arriving at the receiver. High jitter can negatively impact the quality of real-time audio and video.
- **Throughput:** The actual rate at which data is successfully transferred between the sender and receiver. It can be affected by factors like network congestion and the capabilities of the transmission medium.

2.1.3 Components of a Data Communication System

(c) Analyse the Components of a Data Communication System:

A basic data communication system consists of five key components:

- **Sender (Source):** The device that originates the data or message to be transmitted. Examples: a computer, a smartphone, a sensor.
 - **Image:**
 - +-----+
 - | Sender | (Data Originator)
 - +-----+

A picture of a computer acting as a sender.

- **Message:** The information (data) to be communicated. It can be text, audio, video, images, or a combination.
 - **Image:**
 - +-----+
 - | Message | (Information to be Transmitted)
 - +-----+

A representation of a text message.

- **Medium (Communication Channel):** The physical path over which the message travels from the sender to the receiver. Examples: wires, fiber optics, air (for wireless).

- **Image:** (Refer to the communication channel images in 2.1.1)
- **Protocol:** A set of rules that govern the communication process, ensuring that the sender and receiver can understand each other. This includes aspects like data format, transmission rate, and error handling.
 - **Image:** (Refer to the protocol image in 2.1.1)
- **Receiver (Destination):** The device that receives the transmitted message. Examples: a computer, a smartphone, a printer.
 - **Image:**
 - +-----+
 - | Receiver | (Data Destination)
 - +-----+

A picture of a smartphone acting as a receiver.

- **Diagram of Interaction:**
- +-----+ +-----+ +-----+ +-----+ +-----+
- | Sender |----->| Message |----->| Medium |----->| Protocol |----->| Receiver |
- +-----+ +-----+ +-----+ +-----+ +-----+

A block diagram showing the interaction between the components of a data communication system.

2.1.4 Modes of Data Flow

(d) Simulate Modes of Data Flow in Communication Systems:

Data can flow between a sender and a receiver in three primary modes:

- **Simplex:** Data transmission occurs in only one direction. One device is always the sender, and the other is always the receiver. Examples: Radio broadcasting (sender to listeners), television broadcasting.
 - **Simulation:** Imagine a one-way street where traffic can only flow in one direction.
 - **Diagram:**
 - Sender -----> Receiver

A diagram showing data flowing in one direction only.

- **Half-Duplex:** Data can be transmitted in both directions, but only one direction at a time. When one device is sending, the other must wait to receive, and vice versa. Examples: Walkie-talkies (you say "over" to indicate you're done talking and the other person can respond).
 - **Simulation:** Imagine a two-way street that is narrow, allowing traffic to pass in only one direction at a time, controlled by a signal.
 - **Diagram:**
 - Sender <-----> Receiver
 - (One direction at a time)

A diagram showing data flowing in both directions, but not simultaneously.

- **Full-Duplex:** Data can be transmitted in both directions simultaneously. Both devices can send and receive data at the same time. Examples: Telephone conversations, most modern network connections (like internet browsing).
 - **Simulation:** Imagine a two-way street with multiple lanes allowing traffic to flow in both directions at the same time.
 - **Diagram:**
 - Sender <=====> Receiver
 - (Both directions simultaneously)

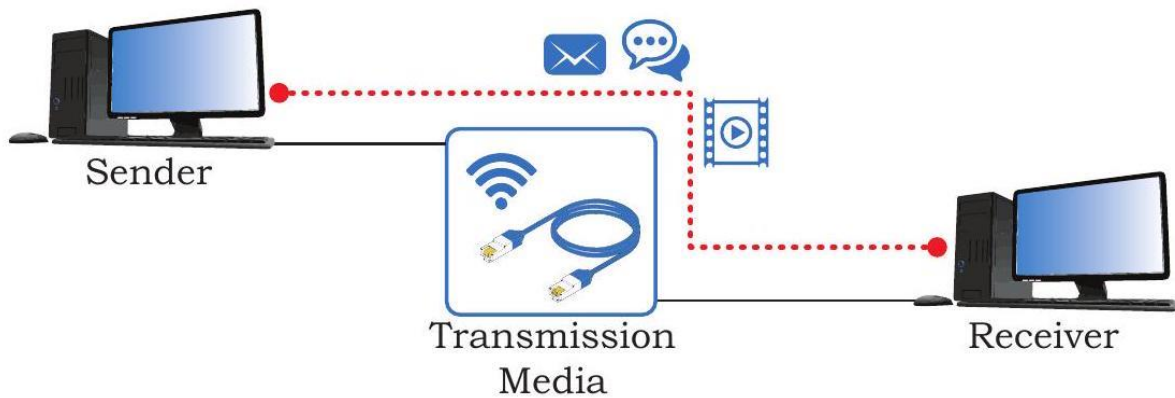

A diagram showing data flowing in both directions simultaneously.

- **Advantages and Disadvantages of Data Communication Modes:**

Mode	Advantages	Disadvantages	Examples
Simplex	- Simple implementation	- No interaction or feedback from the receiver	- Radio broadcasting
	- Full channel capacity used for one-way transmission	- Communication is only in one direction	- TV broadcasting
Half-Duplex	- Two-way communication possible	- Requires coordination to avoid collisions	- Walkie-talkies
	- Suitable for applications where simultaneous two-way communication is not needed	- Slower two-way communication due to the need to switch directions	- Older modems
Full-Duplex	- Efficient two-way communication	- More complex implementation	- Telephone
	- No need for coordination between sender and receiver	- Requires channel capacity in both directions	- Internet
	- Allows for simultaneous sending and receiving of data		- Modern network connections

2.1.5 Significance of Data Communication Systems in Networking

(e) Acknowledge the Significance of Data Communication Systems in Networking:

Data communication systems are the foundation upon which all computer networks are built. Their significance is paramount:

- **Enables Connectivity:** They provide the means for devices to connect and interact with each other, forming networks of various sizes and complexities.
- **Facilitates Resource Sharing:** Through data communication, networks enable the sharing of hardware (printers, scanners), software (applications), and data among connected devices.
- **Supports Information Exchange:** They allow for the transfer of information in various forms (text, images, audio, video) between users and systems.
- **Underpins Internet Functionality:** The internet, a global network, relies entirely on data communication protocols and technologies to enable worldwide connectivity and access to information and services.
- **Drives Modern Applications:** Applications like email, web browsing, social media, online gaming, and cloud computing all depend on robust and efficient data communication systems.
- **Supports Business Operations:** Businesses rely heavily on networks for internal communication, data sharing, customer interaction, and accessing remote resources.
- **Facilitates Automation and Control:** In industrial and other settings, data communication enables the monitoring and control of processes and devices.

2.1.6 Evolution of Data Communication Systems

Data communication systems have undergone a dramatic evolution over time:

- **Early Days (Telegraph and Telephone):** The earliest forms involved electrical signals over wires for text-based communication (telegraph) and voice communication (telephone).
- **Modems and Analog Networks:** The advent of computers led to the use of modems to convert digital data into analog signals for transmission over telephone lines.
- **Digital Networks:** The shift towards digital transmission technologies led to faster and more reliable data communication. Technologies like ISDN emerged.
- **Local Area Networks (LANs):** The development of LAN technologies like Ethernet allowed for high-speed communication between computers within a limited geographical area.
- **The Internet and TCP/IP:** The development of the TCP/IP protocol suite and the growth of the internet revolutionized data communication, enabling global connectivity.
- **Wireless Technologies:** The emergence of wireless technologies like Wi-Fi, Bluetooth, and cellular networks has provided mobility and flexibility in data communication.
- **High-Speed Broadband:** The development of broadband technologies (DSL, cable internet, fiber optics) has significantly increased data rates and enabled bandwidth-intensive applications.
- **Mobile Internet and 5G:** The proliferation of smartphones and the rollout of high-speed mobile networks (like 5G) have made high-speed data communication ubiquitous.
- **Cloud Computing and IoT:** Modern trends like cloud computing and the Internet of Things (IoT) are driving further evolution in data communication to handle massive amounts of data and connect diverse types of devices.

SUB-STRAND 2.2: DATA TRANSMISSION MEDIA

2.2.1 Basic Concepts in Data Transmission

Data transmission is the process of transferring data between two or more points in a communication system.

(a) Define Basic Concepts Used in Data Transmission:

- **Transmission:** The act of conveying data from one point to another. This involves encoding the data into signals suitable for the transmission medium.
- **Transmission Media:** The physical pathway (guided) or the environment (unguided) through which data signals are propagated. Examples include cables, air, and vacuum.
- **Encoding:** The process of converting data into a specific format or code suitable for transmission. This might involve representing binary data as electrical voltages, light pulses, or radio waves.

- **Illustration:**

- Data (e.g., 10110) ----> Encoder ----> Signal (e.g., Voltage Levels)

A simple diagram showing data being converted into a signal.

- **Decoding:** The reverse process of encoding, where the signal received is converted back into the original data format.

- **Illustration:**

- Signal (e.g., Voltage Levels) ----> Decoder ----> Data (e.g., 10110)

A simple diagram showing a signal being converted back into data.

- **Modulation:** The process of varying one or more properties of a carrier wave (a high-frequency signal) with the information signal to be transmitted. This is often used for analog transmission. Types include Amplitude Modulation (AM), Frequency Modulation (FM), and Phase Modulation (PM).

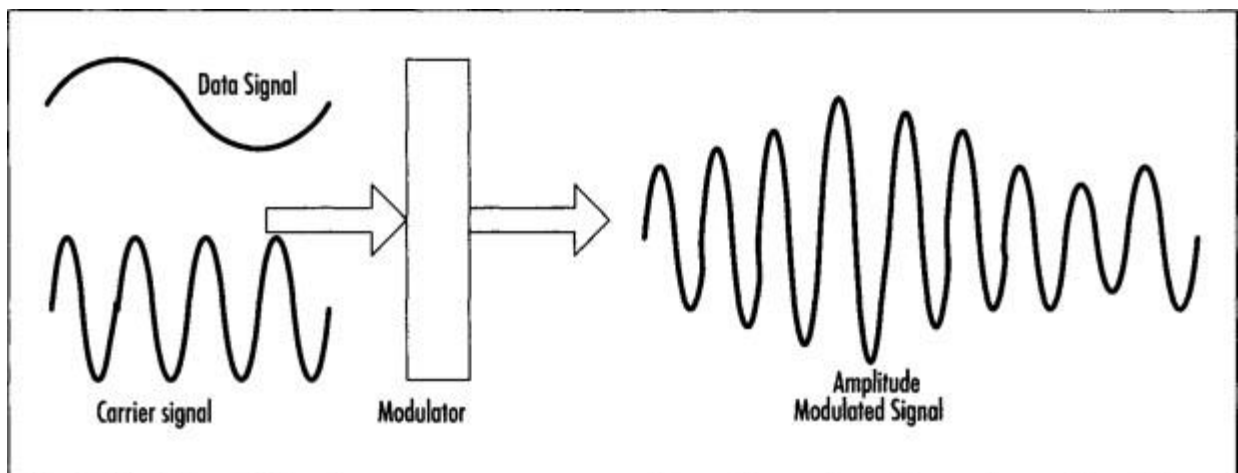

A simplified diagram showing how the amplitude of a carrier wave is varied by a data signal.

- **Demodulation:** The process of extracting the original information signal from the modulated carrier wave at the receiver.

- **Illustration:**

- Modulated Wave ----> Demodulator ----> Data Signal

A simple diagram showing the extraction of the data signal from a modulated wave.

- **Multiplexing:** The technique of combining multiple data signals onto a single transmission medium simultaneously, allowing for efficient use of the available bandwidth. Types include Frequency Division Multiplexing (FDM), Time Division Multiplexing (TDM), and Wavelength Division Multiplexing (WDM).

- **Illustration (Time Division Multiplexing):**

- Data 1: |A|A|A|A|
 - Data 2: |B|B|B|B|
 - Data 3: |C|C|C|C|
 - ----- (Time)
 - Multiplexed Signal: |A|B|C|A|B|C|A|B|C|

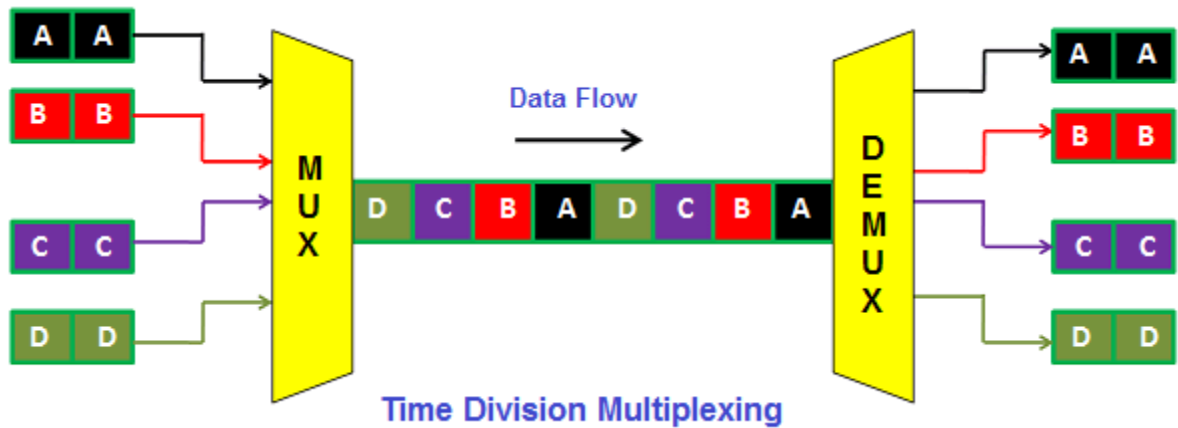

A

simplified diagram showing how data from multiple sources is interleaved in time.

- **Demultiplexing:** The process at the receiver of separating the combined signals back into their original individual signals.

- **Illustration:**

- Multiplexed Signal ----> Demultiplexer ----> Data 1, Data 2, Data 3

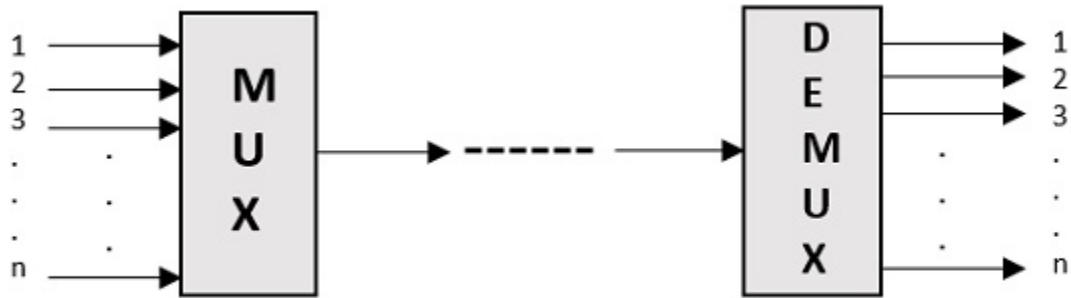

Multiplexing and Demultiplexing

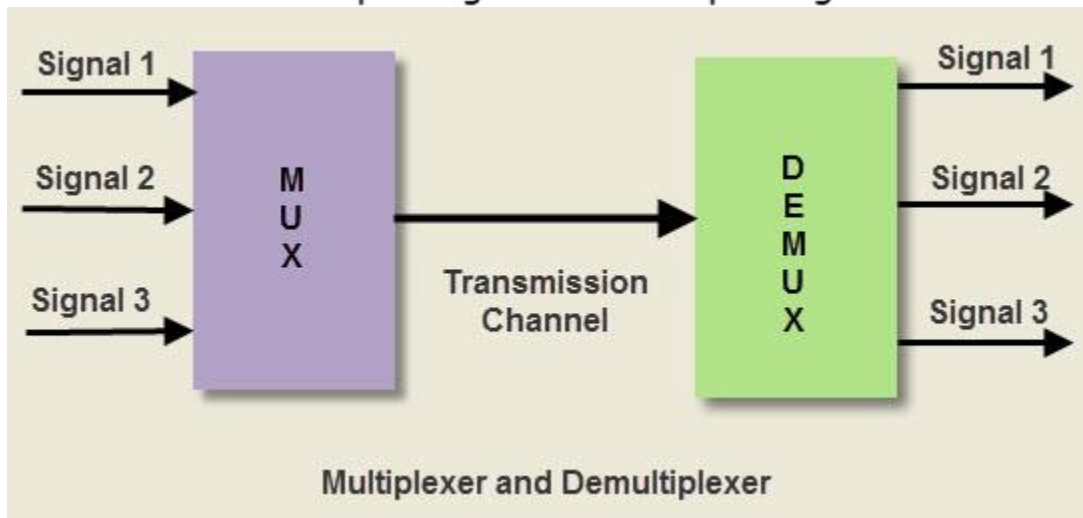

A simple

Multiplexer and Demultiplexer

diagram

showing the separation of multiplexed signals into their original data streams.

2.2.2 Types of Transmission Media

(b) Describe Types of Transmission Media Used in Computer Networks:

Transmission media can be broadly classified into two categories: guided (wired) and unguided (wireless).

- **Guided Media (Wired):** Physical cables that guide the data signals along a specific path.
 - **Twisted Pair Cable:** Consists of two insulated copper wires twisted together to reduce electromagnetic interference (EMI) and crosstalk. Commonly used for Ethernet connections.
 - **Types:** Unshielded Twisted Pair (UTP) and Shielded Twisted Pair (STP). STP has a metallic shield for better EMI protection.



A cross-section of a twisted pair cable.

- **Coaxial Cable:** Has a central copper conductor surrounded by an insulating layer, a braided metal shield, and an outer jacket. Offers better EMI protection and higher bandwidth than UTP. Used for cable television and older Ethernet networks.



A cross-section of a coaxial cable showing its layers.

- **Fiber Optic Cable:** Transmits data as light pulses through thin strands of glass or plastic fibers. Offers very high bandwidth, low attenuation, and immunity to EMI. Used for high-speed internet, long-distance communication, and network backbones.

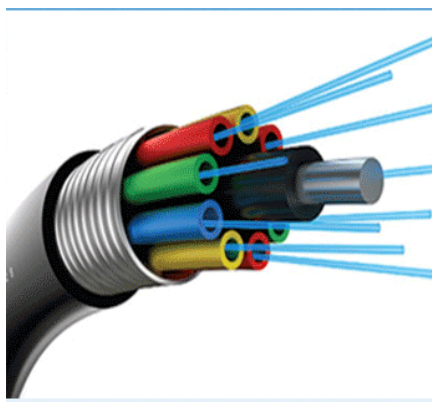

A cross-section of a fiber optic cable showing the core and cladding.

- **Unguided Media (Wireless):** Transmits data through the air or space using electromagnetic waves.

- **Radio Waves:** Electromagnetic waves in the frequency range of 3 kHz to 300 GHz. Used for Wi-Fi, Bluetooth, cellular communication, and radio broadcasting.
 - **Illustration:** (Refer to the radio waves image in 2.1.1)
- **Microwaves:** Electromagnetic waves in the frequency range of 1 GHz to 300 GHz. Used for satellite communication, microwave ovens, and some wireless LANs.
 - **Types:** Terrestrial microwaves (ground-based antennas) and satellite microwaves (communication via satellites).



A simplified representation of a microwave dish antenna.

- **Infrared (IR):** Electromagnetic waves with frequencies higher than microwaves but lower than visible light. Used for short-range communication, such as remote controls and some wireless data transfer between devices.
 - **Illustration (IR Transmission):**
 - [Device A] ---> (Invisible IR Light) ---> [Device B]



A simple diagram showing infrared communication between two devices.

2.2.3 Connecting Digital Devices

(c) Connect Digital Devices Used in Data Communication:

Connecting digital devices involves using the appropriate cables and ports based on the type of transmission media and the devices involved. Examples include:

- **Connecting computers to a wired network:** Using Ethernet cables (RJ-45) to connect the network interface card (NIC) of the computer to a port on a router or switch.
- **Connecting a computer to a monitor:** Using HDMI, DisplayPort, DVI, or VGA cables depending on the available ports on both devices.
- **Connecting peripherals (keyboard, mouse, printer) to a computer:** Using USB cables.
- **Establishing a Wi-Fi connection:** Selecting the correct wireless network (SSID) and entering the password (if required) on the device.
- **Pairing Bluetooth devices:** Putting both devices in pairing mode and selecting the other device from the list of available devices.

Safety Rules During Connection:

- **Power Off:** Ensure all devices are powered off before connecting or disconnecting cables to prevent electrical shock or damage.
- **Gentle Handling:** Handle cables and connectors gently to avoid bending pins or damaging the connectors.
- **Correct Ports:** Always plug a cable into the correct port. Forcing a connector can cause damage.
- **Grounding:** In some cases, especially with older equipment, proper grounding may be necessary to prevent electrical hazards.
- **Read Manuals:** Refer to the user manuals of the devices for specific connection instructions and safety precautions.

2.2.4 Factors Affecting Communication Over a Computer Network

(d) Establish Factors that Affect Communication Over a Computer Network:

Several factors can impact the quality and speed of data transmission over a computer network:

- **Bandwidth:** The capacity of the transmission medium to carry data. Higher bandwidth allows for faster data transfer rates.
- **Attenuation:** The loss of signal strength as it travels over a distance. This can be a significant issue with wired media over long distances and may require repeaters or amplifiers.
- **Noise:** Unwanted signals that interfere with the data signal. Sources of noise include electromagnetic interference (EMI), radio frequency interference (RFI), and crosstalk.
- **Latency:** The delay experienced by data as it travels from the sender to the receiver. High latency can affect the responsiveness of applications, especially real-time ones.
- **Jitter:** Variations in the delay of packets arriving at the receiver, which can disrupt real-time audio and video streams.
- **Interference:** External signals that disrupt wireless transmissions, such as signals from other wireless networks or electronic devices.
- **Distance:** The length of the transmission medium can affect signal strength and latency.
- **Obstructions (for wireless):** Physical barriers like walls, buildings, and terrain can weaken or block wireless signals.

- **Network Congestion:** When too many devices try to use the same network resources simultaneously, it can lead to delays and reduced throughput.
- **Quality of Hardware and Cables:** Using low-quality cables or network equipment can introduce errors and reduce performance.

Ways of Overcoming Transmission Impairments:

- **Repeaters and Amplifiers:** Used to boost signal strength over long distances in wired networks.
- **Shielding:** Used in cables (STP, coaxial) to reduce EMI and crosstalk.
- **Error Detection and Correction:** Protocols often include mechanisms to detect and correct errors introduced during transmission.
- **Signal Processing Techniques:** Advanced modulation and encoding techniques can improve signal-to-noise ratio.
- **Using Higher Quality Media:** Fiber optic cables offer better performance over long distances with less attenuation and noise.
- **Strategic Placement of Wireless Access Points:** Optimizing the location of Wi-Fi routers can improve signal coverage and reduce interference.
- **Traffic Management Techniques:** Network devices can prioritize traffic and manage congestion.

2.2.5 Role of Transmission Media in Computer Networking

(e) Appreciate the Role of Transmission Media in Computer Networking:

Transmission media are absolutely fundamental to computer networking. They provide the physical or wireless pathways that enable communication between devices. Without transmission media:

- **No Connection:** Devices would be isolated and unable to exchange data.
- **No Networks:** The formation of local area networks (LANs), wide area networks (WANs), and the internet would be impossible.
- **Limited Functionality:** The benefits of networking, such as resource sharing, information access, and communication, would not be realized.

SUB-STRAND 2.3: COMPUTER NETWORK ELEMENTS

2.3.1 Types of Computer Networks

Computer networks can be classified based on their geographical scope, architecture, and purpose.

(a) Identify Different Types of Computer Networks:

- **PAN (Personal Area Network):** A network organized around an individual person, typically within a range of a few meters. Used to connect personal devices. Examples: Bluetooth connection between a phone and headphones, a USB connection between a computer and a printer, an infrared connection between a remote and a TV.

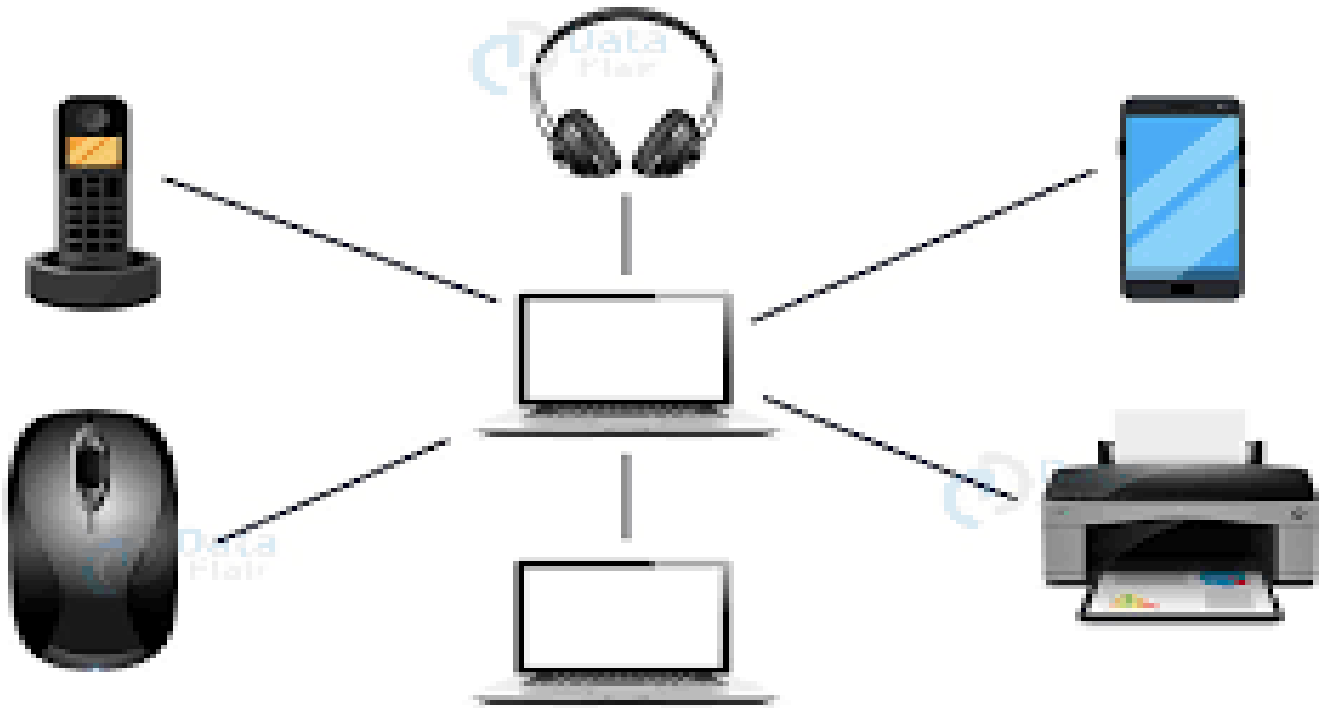

A diagram showing various personal devices connected in a PAN.

- **LAN (Local Area Network):** A network that connects computers and devices within a limited geographical area, such as an office, school, or home. Typically uses wired (Ethernet) or wireless (Wi-Fi) connections.

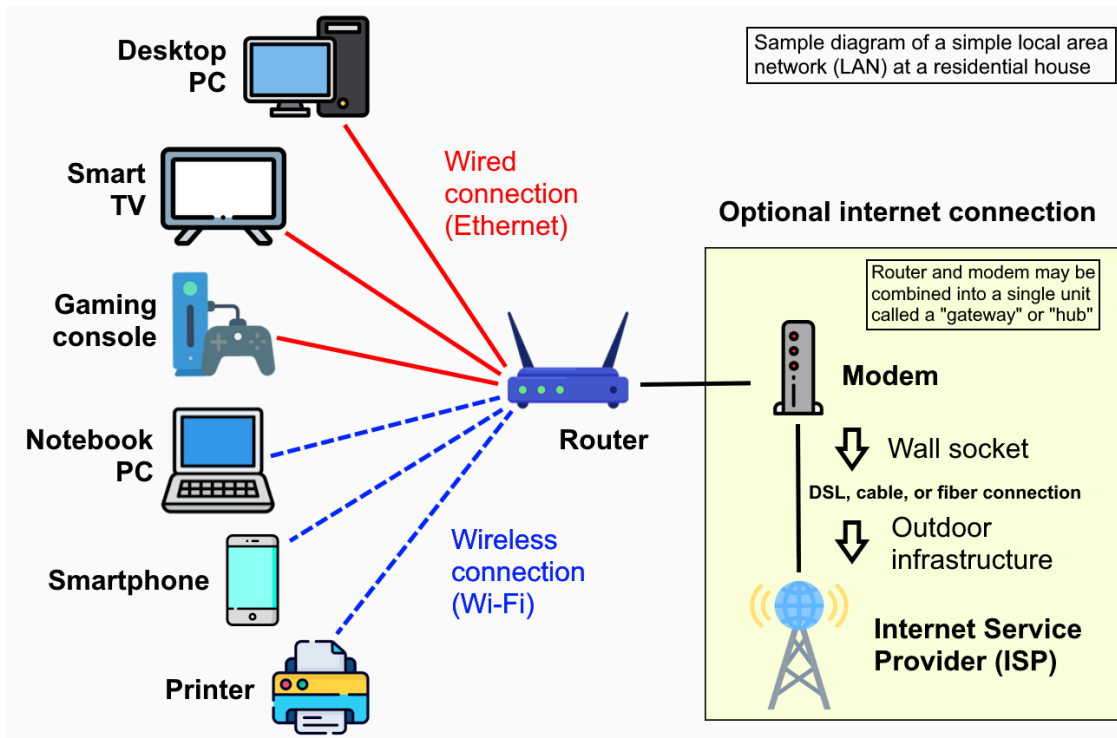

A diagram showing devices connected in a LAN using both wired and wireless connections.

- **WLAN (Wireless Local Area Network):** A type of LAN that uses wireless technologies (like Wi-Fi) to connect devices within a limited area.



A diagram showing devices connected wirelessly in a WLAN.

- **MAN (Metropolitan Area Network):** A network that covers a larger geographical area than a LAN, such as a city or metropolitan region. Often connects multiple LANs. Examples: Cable TV networks, some large corporate networks spanning several buildings in a city.

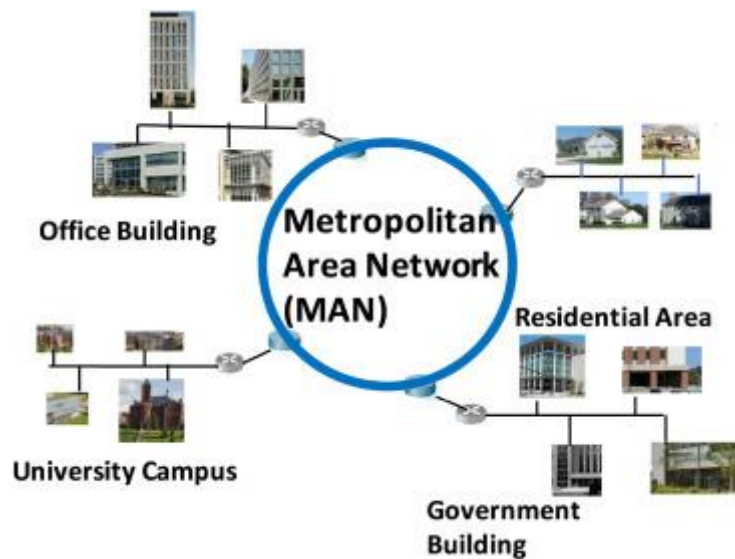

A diagram showing multiple LANs interconnected by a MAN backbone.

- **WAN (Wide Area Network):** A network that spans a large geographical area, often across countries or continents. The internet is the largest example of a WAN. WANs typically use various communication technologies, including fiber optic cables, satellite links, and leased telephone lines.

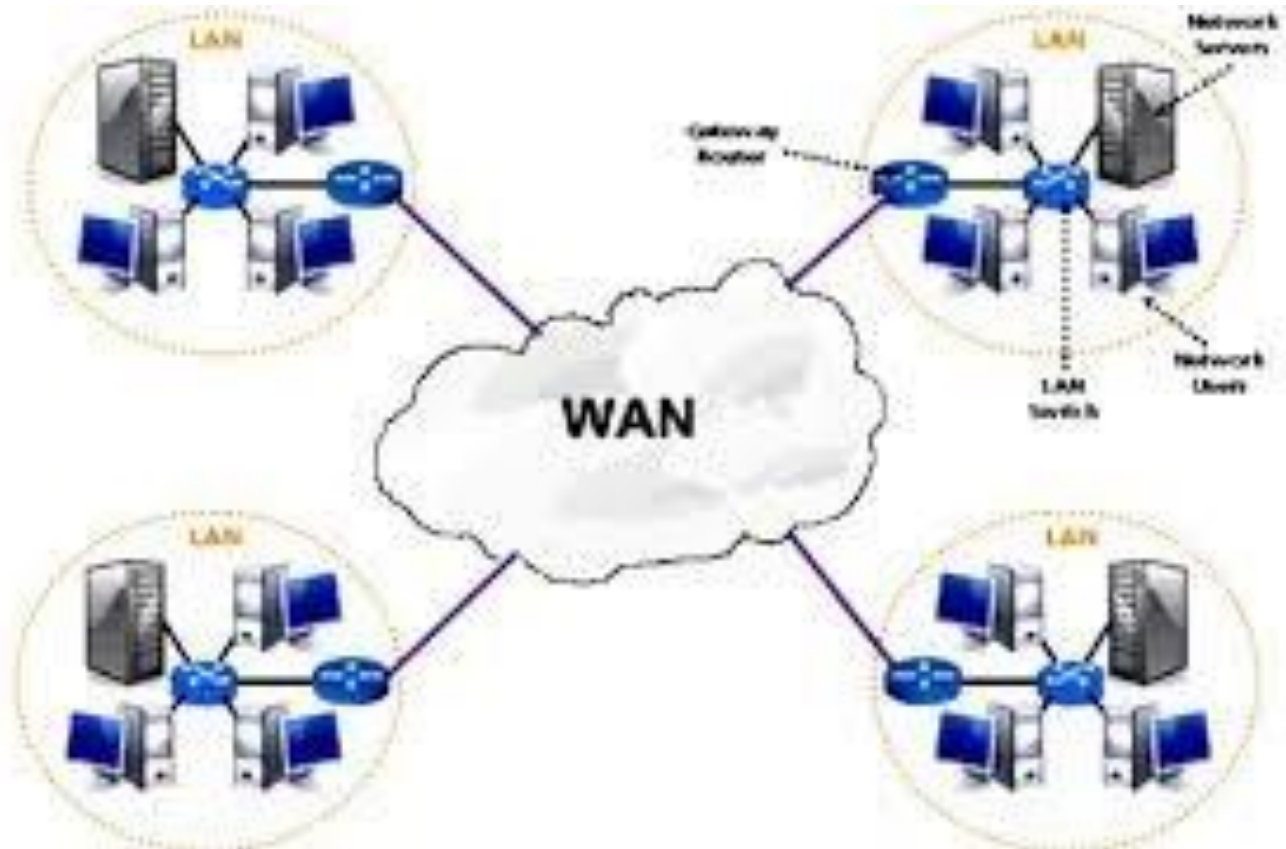

A diagram showing LANs and remote users connected via the internet (a WAN).

2.3.2 Elements of a Computer Network

(b) Describe Elements of a Computer Network:

A computer network is comprised of several key elements that work together to enable communication:

- **Transmission Media:** The physical or wireless pathways that carry data signals (e.g., Ethernet cables, fiber optic cables, radio waves). (Covered in Sub-strand 2.2)
- **DTE (Data Terminal Equipment):** End devices that generate or receive data. Examples: Computers (desktops, laptops), smartphones, printers, servers.
 - **Image (Various DTEs):**
 - [Computer] [Smartphone] [Printer] [Server]



A collection of images showing different types of DTE.

- **DCE (Data Circuit-terminating Equipment):** Devices that provide the interface between the DTE and the communication medium. Examples: Modems, network interface cards (NICs).
 - **Image (DCEs):**
 - [Modem] [Network Interface Card (NIC)]

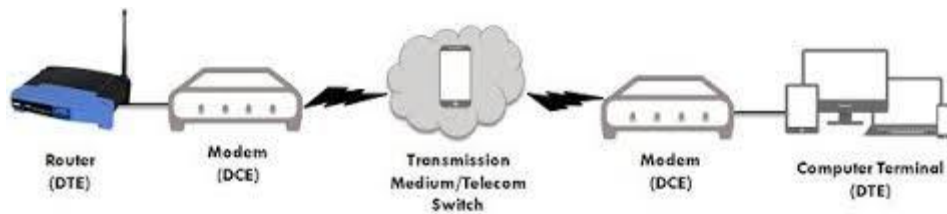

Images of a modem and a network interface card.

- **Network Devices:** Hardware components used to connect devices and facilitate communication within the network. Examples:
 - **NIC (Network Interface Card):** A hardware component in a computer that allows it to connect to a network. Can be wired (Ethernet) or wireless (Wi-Fi adapter).
 - **Image:** (Refer to the NIC image above)
 - **Hub:** A simple networking device that connects multiple devices in a LAN. It receives incoming signals on one port and broadcasts them to all other ports. Less efficient than switches.

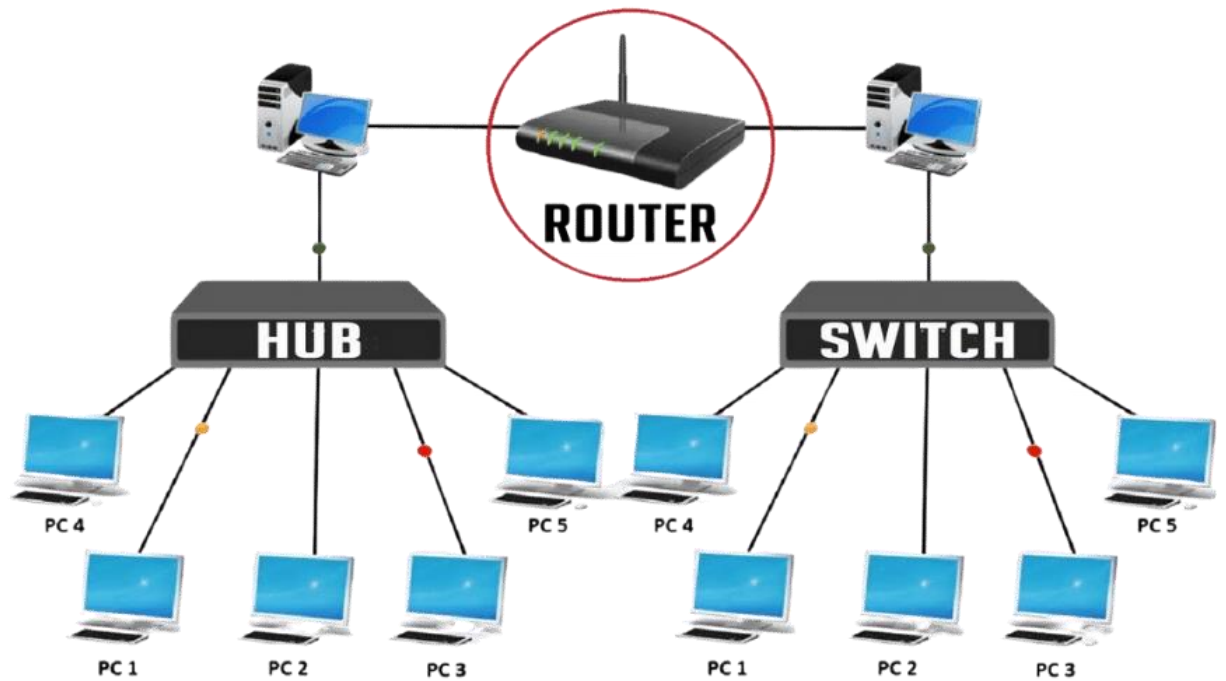

A diagram showing devices connected to a hub.

- **Switch:** A more intelligent networking device than a hub. It learns the MAC addresses of connected devices and forwards data only to the intended destination port, improving efficiency.

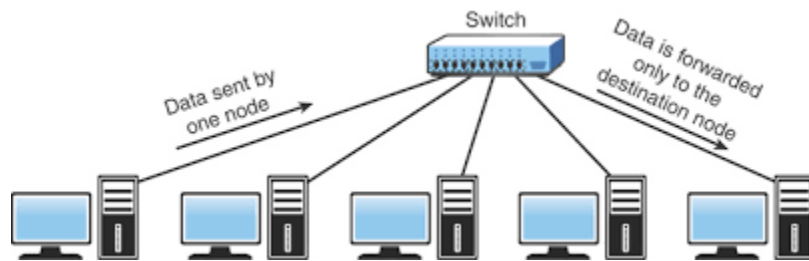

A diagram showing devices connected to a switch.

- **Router:** A device that forwards data packets between different networks. It uses routing tables to determine the best path for data to travel. Essential for connecting LANs to the internet.

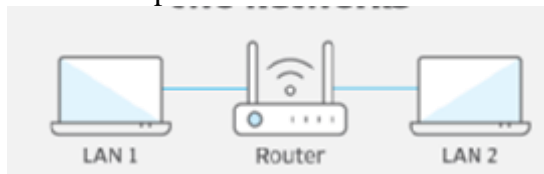

A diagram showing a router connecting a LAN to the internet.

- **Modem (Modulator-Demodulator):** A device that converts digital signals from a computer into analog signals for transmission over analog communication lines (like telephone lines) and vice versa. Less common with broadband internet.
 - **Image:** (Refer to the modem image above)

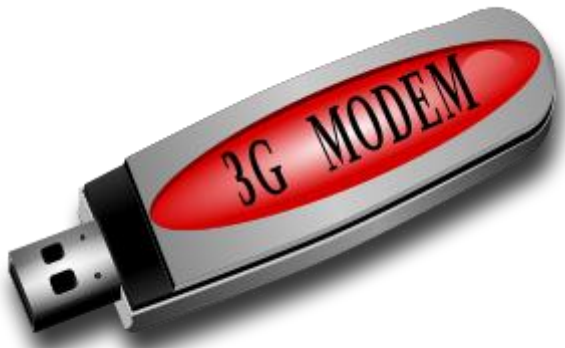

- **Bridge:** A device that connects two LANs that use the same protocol. It forwards data based on MAC addresses.

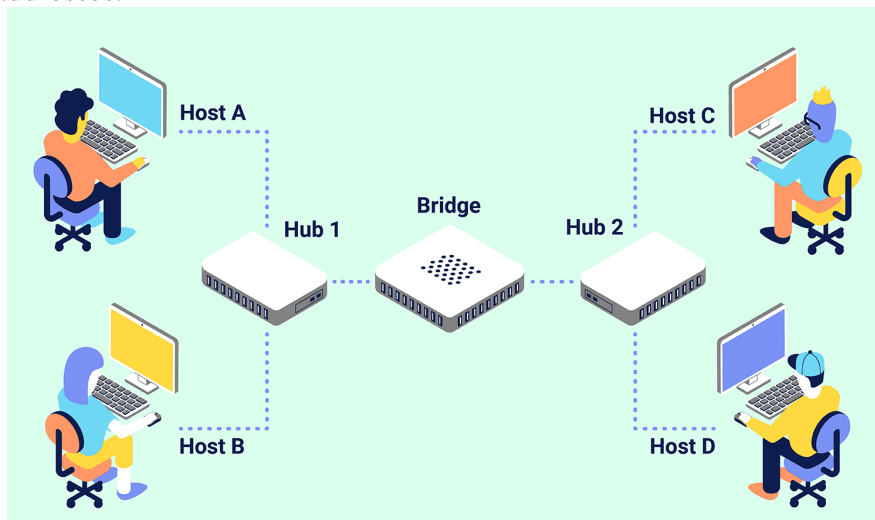

A diagram showing two LANs connected by a bridge.

- **Gateway:** A device that connects networks using different protocols. It performs protocol conversion to enable communication between disparate systems.
 - **Diagram:**
 - [Network A (Protocol 1)] --- Gateway --- [Network B (Protocol 2)]



A diagram

showing a gateway connecting two networks with different protocols.

- **Repeater:** A device that receives a signal, amplifies it, and retransmits it to extend the range of a network segment, combating attenuation.
 - **Diagram:**
 - Signal ---> [Repeater] ---> Stronger Signal --->

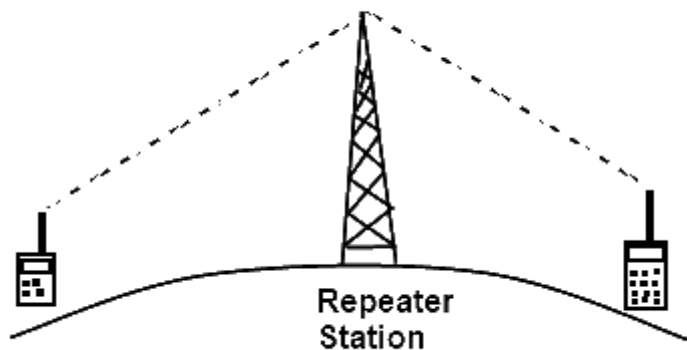

A diagram illustrating a repeater amplifying a network signal.

- **Network Software:** Programs that enable communication and resource sharing over a network. Examples:
 - **Network Operating System (NOS):** An OS designed to manage network resources and user access (e.g., Windows Server, Linux Server).
 - **Web Browsers:** Applications used to access and display web pages (e.g., Chrome, Firefox, Safari).
 - **Search Engines:** Online tools used to find information on the internet (e.g., Google, Bing).
 - **Email Clients:** Applications used to send and receive emails (e.g., Outlook, Thunderbird).

- **Communication Protocols:** Sets of rules that govern data transmission over the network (e.g., TCP/IP, HTTP, SMTP, FTP).

2.3.3 Criteria of a Computer Network

(c) Evaluate Criteria of a Computer Network:

The quality and effectiveness of a computer network can be evaluated based on several criteria:

- **Performance:** Measured by factors like data transfer rate (bandwidth), throughput (actual data transfer), latency (delay), and jitter (delay variation). A good network offers high speed and low delays.
- **Security:** The ability of the network to protect data and resources from unauthorized access, use, disclosure, disruption, modification, or destruction. Includes measures like firewalls, intrusion detection systems, and encryption.
- **Scalability:** The ease with which the network can be expanded to accommodate more users and devices without significant degradation in performance or increased complexity.
- **Reliability:** The consistency and dependability of the network. A reliable network experiences minimal downtime and ensures consistent data delivery.
- **Availability:** The percentage of time the network and its resources are accessible to users. High availability is crucial for critical applications.
- **Cost:** The total expense of setting up, maintaining, and upgrading the network infrastructure, including hardware, software, and personnel.

2.3.4 Connecting to a Computer Network

(d) Connect a Computing Device to an Available Network:

Connecting a device to a network depends on whether it's a wired or wireless connection:

- **Wired Connection (Ethernet):**
 1. Ensure you have an Ethernet cable (RJ-45).
 2. Locate the Ethernet port on your computing device (usually on the back or side, looks like a wider phone jack).
 3. Locate an available Ethernet port on the network infrastructure (router, switch, or wall socket connected to the network).
 4. Plug one end of the Ethernet cable into the port on your device and the other end into the port on the network infrastructure.
 5. Your device should automatically attempt to establish a network connection. You may need to configure IP address settings (usually automatically via DHCP).
- **Wireless Connection (Wi-Fi):**
 1. Ensure your device has Wi-Fi capability enabled.
 2. Open the list of available Wi-Fi networks (SSIDs) on your device (usually in the network settings).
 3. Select the network you want to connect to.
 4. If the network is secured, you will be prompted to enter the Wi-Fi password (network key).
 5. Once you enter the correct password, your device should connect to the wireless network.

- **Sharing Data Through Different Network Setups:** Once connected, you can share data through various methods depending on the network and operating system:
 - **Shared Folders:** Configuring folders on your computer to be accessible by other users on the same local network.
 - **Network Drives:** Mapping shared folders as virtual drives for easier access.
 - **File Transfer Protocol (FTP):** Using FTP clients and servers to upload and download files.
 - **Cloud Storage Services:** Sharing files via platforms like Google Drive, Dropbox, or OneDrive (requires internet access).
 - **Email:** Sending files as attachments.
 - **Messaging Apps:** Sharing files through network-based messaging applications.
- **Observing Online Safety Rules:** When sharing resources through a computer network, especially the internet, it's crucial to follow online safety rules:
 - **Use strong passwords:** Protect your accounts and shared resources with robust, unique passwords.
 - **Be cautious of what you share:** Avoid sharing sensitive personal information publicly.
 - **Use secure connections (HTTPS):** When accessing websites or services that require login or involve sensitive data, ensure the connection is encrypted (HTTPS).
 - **Be aware of phishing and malware:** Do not click on suspicious links or download files from untrusted sources.
 - **Use antivirus and firewall software:** Protect your devices from malicious software and unauthorized access.
 - **Keep software updated:** Regularly update your operating system and applications to patch security vulnerabilities.
 - **Respect privacy settings:** Understand and configure privacy settings on online services.

2.3.5 Role of Computer Networks in Communication

(e) Appreciate the Role of Computer Networks in Communication:

Computer networks have revolutionized communication in numerous ways:

- ✓ **Instant Communication:** Networks enable real-time communication through email, instant messaging, video conferencing, and voice over IP (VoIP).
- ✓ **Global Connectivity:** The internet, a vast network of networks, connects people and information across the globe, breaking down geographical barriers.
- ✓ **Information Sharing:** Networks facilitate the easy sharing of information, resources, and knowledge among individuals, organizations, and communities.
- ✓ **Collaboration:** Networks support collaborative work environments, allowing teams to work on projects simultaneously from different locations.
- ✓ **Access to Information and Services:** The internet provides access to a vast array of information, educational resources, entertainment, and online services (e-commerce, online banking, etc.).
- ✓ **Business Operations:** Businesses rely heavily on networks for internal communication, customer interaction, supply chain management, and accessing global markets.
- ✓ **Education and Research:** Networks connect students, educators, and researchers, enabling access to remote learning resources and facilitating collaboration on research projects.
- ✓ **Social Interaction:** Social media platforms and online communities built on networks allow people to connect and interact with others who share similar interests.

SUB-STRAND 2.4: NETWORK TOPOLOGIES

2.4.1 Introduction to Network Topologies

A network topology refers to the way in which the components of a network are interconnected. It describes the layout of devices, cables, and wireless links, as well as the path that data follows between devices.

(a) Differentiate Between Physical and Logical Network Topologies:

- Physical Topology:** Refers to the actual physical layout of the network components, including the cables, devices, and their physical connections. It describes how the network devices are physically arranged and interconnected.

Analogy: Think of the physical streets and roads connecting buildings in a city.

Illustration:

```
[Computer A] ----- Cable ----- [Hub/Switch] ----- Cable ----- [Computer B]
```

A simple diagram showing the physical connection between two computers via a central device.

- Logical Topology:** Refers to the conceptual way in which data flows through the network, regardless of the physical arrangement of the devices. It describes how devices communicate with each other and how data is transmitted.

Analogy: Think of the routes and directions you take to get from one building to another in the city, which might not directly follow the physical street layout.

Illustration (Logical Bus over Physical Star):

```

[Computer A]
  /
  /
[Computer B] --- (Central Hub/Switch) --- [Computer C]
  \
  \
[Computer D]
  
```

Physically a star, but logically data might be broadcast to all (like a bus). A diagram showing a physical star topology where data is logically broadcast as in a bus topology.

Key Differences Summarized:

Feature	Physical Topology	Logical Topology
Focus	Actual physical arrangement and connections	Conceptual flow of data
Description	How devices are physically connected by	How data is transmitted and received between

	cables	devices
Examples	Bus, Star, Ring, Mesh, Tree, Hybrid	Broadcast, Token Passing, Point-to-Point, Client-Server
Visibility	Tangible, can be seen and touched	Intangible, describes data communication patterns

Export to Sheets

2.4.2 Types of Logical and Physical Network Topologies

(b) Describe Types of Logical and Physical Computer Network Topologies:

Physical Topologies:

- **Bus Topology:** All devices are connected to a single cable, called the bus. Data is transmitted along the bus, and all devices receive the signal, but only the intended recipient processes it. Older technology, less common now.

Illustration:

```
[Computer A] --- [Connector] --- [Bus Cable] --- [Connector] --- [Computer B] ---
[Connector] --- [Computer C] --- [Terminator]
```

A diagram showing computers connected to a single bus cable terminated at both ends.

- ✓ **Advantages:** Simple to install and inexpensive for small networks.
- ✓ **Disadvantages:** Single point of failure (the bus), difficult to troubleshoot, limited bandwidth, performance degrades as more devices are added.
- **Star Topology:** All devices are connected to a central hub or switch. All communication passes through the central device. Most common topology for LANs.

Illustration:

```

[Computer A]
  /  |  \
 /   |   \
[Computer B] --- Hub/Switch --- [Computer C]
  \   |   /
   \  |  /
[Computer D]
```

A diagram showing computers connected to a central hub or switch.

- ✓ **Advantages:** Easy to troubleshoot (failure of one device or cable doesn't affect others), easy to add or remove devices, centralized management.
- ✓ **Disadvantages:** Single point of failure (the central hub/switch), more cabling required than bus.

- **Ring Topology:** Devices are connected in a closed loop or ring. Data travels around the ring in one direction, passing through each device until it reaches its destination. Often uses token passing to control access.

Illustration:

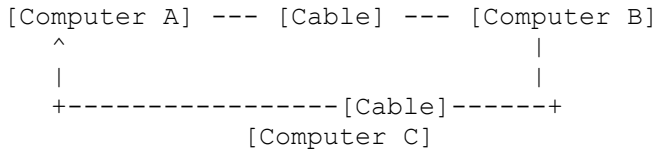

A diagram showing computers connected in a closed ring.

- ✓ **Advantages:** Relatively easy to install and manage, performs well under heavy load (with token passing).
- ✓ **Disadvantages:** Single point of failure (a break in the ring can disrupt the entire network), troubleshooting can be difficult, adding or removing devices can disrupt the network.
- **Mesh Topology:** Every device is connected to every other device in the network. Provides high redundancy and fault tolerance. Expensive and complex to implement.

Illustration (Partial Mesh):

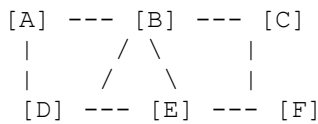

A diagram showing a partially meshed network where not all devices are directly connected.

Illustration (Full Mesh):

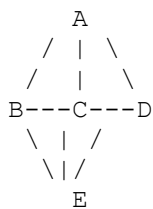

In a full mesh, every node has a direct connection to every other node. A diagram showing a fully meshed network where every device is directly connected to every other device.

- ✓ **Advantages:** Highly redundant (multiple paths for data), very fault-tolerant, good for high-traffic networks.

- ✓ **Disadvantages:** Very expensive (many cables and interfaces required), complex to install and manage.
- **Tree Topology:** A combination of star and bus topologies. Multiple star networks are connected to a central bus. Can extend the reach of a star network but inherits characteristics of both.

Illustration:

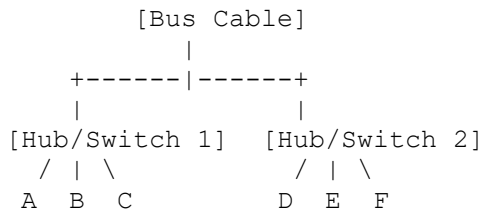

A diagram showing multiple star networks connected to a central bus.

- ✓ **Advantages:** Easy to expand from a star network, hierarchical management.
- ✓ **Disadvantages:** Failure of the bus can affect the entire network, more complex than pure star.
- **Hybrid Topology:** A combination of two or more different physical topologies. Allows for flexibility in network design. Example: A star topology connected to a bus topology.
 - ✓ **Illustration:** (See Tree Topology as an example of a hybrid)
 - ✓ **Advantages:** Flexible, can be tailored to specific needs.
 - ✓ **Disadvantages:** Can be complex to design and manage.

Logical Topologies:

- ✓ **Broadcast Topology:** Data is sent out to all devices on the network, and each device checks the destination address to see if it should process the data. Common in bus and some wireless (Wi-Fi) networks.
 - **Analogy:** A public announcement made over a loudspeaker, where everyone hears it, but only those for whom it's intended will respond.
- ✓ **Token Passing Topology:** A special signal called a "token" circulates around the network. A device can only transmit data when it holds the token. Common in ring networks (like Token Ring).
 - **Analogy:** A microphone being passed around a meeting room; only the person holding the microphone can speak.
- ✓ **Point-to-Point Topology:** A direct connection between two devices. Data travels directly between these two points. Forms the basis of many WAN links and some LAN connections.
 - **Analogy:** A direct phone call between two people.
- ✓ **Client-Server Topology:** One or more central servers provide resources or services to client devices. Clients request services from the server. Common in many network applications (e.g., web browsing, file sharing).
 - **Analogy:** Customers (clients) requesting food from a waiter (server) in a restaurant.

2.4.3 Creating a Physical Network Topology

(c) Create a Physical Network Topology for a Computer Network:

Creating a physical network topology involves deciding on the arrangement of devices and the cabling infrastructure. The choice depends on factors like:

- ✓ **Size of the Network:** Small networks might use a bus or star, while larger ones might use a tree or a combination (hybrid).
- ✓ **Cost:** Bus is generally the cheapest for small networks, while mesh is the most expensive. Star is a good balance.
- ✓ **Reliability Requirements:** Mesh offers the highest reliability due to redundancy. Star is more reliable than bus.
- ✓ **Ease of Expansion:** Star and tree topologies are generally easier to expand.
- ✓ **Ease of Troubleshooting:** Star topology is usually the easiest to troubleshoot.
- ✓ **Performance Requirements:** Star and mesh topologies generally offer better performance than bus, especially under heavy load.

Steps to Create a Physical Network Topology (Example: Small Office LAN using Star Topology):

1. **Identify the Devices:** Determine all the computers, printers, servers, and other network devices that need to be connected. (e.g., 5 computers, 1 printer, 1 network storage device).
2. **Choose the Central Device:** Select a network switch with enough ports to accommodate all the devices (e.g., an 8-port Ethernet switch).
3. **Determine Cabling:** Decide on the type and length of Ethernet cables needed to connect each device to the switch. Measure the distances to ensure sufficient cable length.
4. **Physical Connections:**
 - ✓ Place the switch in a central location.
 - ✓ Run an Ethernet cable from the network port (NIC) of each computer to an available port on the switch.
 - ✓ Run an Ethernet cable from the network port of the printer to an available port on the switch.
 - ✓ Run an Ethernet cable from the network port of the network storage device to an available port on the switch.
5. **Power Connections:** Ensure all devices (computers, printer, network storage, switch) are connected to a power source.
6. **Documentation:** Create a diagram showing the physical layout and connections for future reference and troubleshooting.

(d) Simulate a Physical Network Topology Using Available Devices:

This can be done practically in a lab setting with computers, a switch/hub, and Ethernet cables, or using network simulation software (like Packet Tracer). The simulation would involve physically connecting the devices according to the chosen topology (e.g., star) and observing how data is transmitted.

2.4.4 Appreciation of Network Topologies

(d) Appreciate the Use of Network Topologies in Computer Networks:

Network topologies are crucial for the design, implementation, and management of computer networks. They:

- ✓ **Provide Structure:** Define the organization and interconnection of network components.
- ✓ **Affect Performance:** Influence data transmission speed, efficiency, and potential bottlenecks.
- ✓ **Impact Reliability:** Determine the network's fault tolerance and ability to continue operating despite device or link failures.
- ✓ **Influence Scalability:** Affect how easily the network can be expanded or modified.
- ✓ **Guide Troubleshooting:** The topology helps in understanding the data flow and identifying potential points of failure.
- ✓ **Inform Cost Considerations:** The choice of topology affects the amount of cabling, hardware, and complexity, thus impacting the overall cost.

STRAND 3.0: SOFTWARE DEVELOPMENT

SUB-STRAND 3.1: COMPUTER PROGRAMMING CONCEPTS

3.1.1 Basic Programming Terminologies

(a) Explain the Terminologies Used in Programming Languages:

- **Programming:** The process of creating a set of instructions that tells a computer how to perform a specific task or solve a problem. These instructions are written in a programming language.
 - ✓ **Analogy:** Like writing a recipe with a sequence of steps to bake a cake.
- **Programming Language:** A formal language comprising a set of rules (syntax) and vocabulary (keywords) that allows programmers to communicate instructions to a computer. Examples include Python, Java, C++, and JavaScript.
 - ✓ **Image:**

```
("Hello, World!")
```

A simple line of Python code.

- **Language Translator:** A program that converts code written in one programming language into another language, typically into machine code that the computer can directly execute. There are two main types:
 - ✓ **Assembler:** A translator that converts assembly language (a low-level language) into machine code.
 - **Diagram:**
 - Assembly Language Code ----> Assembler ----> Machine Code
 - (e.g., ADD A, B) (Translator) (e.g., 00101011)

A block diagram showing the function of an assembler.

- ✓ **Compiler:** A translator that converts the entire source code of a high-level programming language into machine code or an intermediate code before execution. The compiled code can then be executed multiple times without recompilation.

```
Source Code (High-Level) ----> Compiler ----> Machine Code (or Intermediate Code)
(e.g., Python, Java) (Translator) (Executable)
```

A block diagram showing the function of a compiler.

- ✓ **Interpreter:** A translator that reads and executes source code line by line. It does not create a separate executable file. Each time the program runs, the interpreter translates and executes each instruction.

```
Source Code (High-Level) ----> Interpreter ----> Execution (Line by Line)
(e.g., Python, JavaScript) (Translator & Executor)
```

A block diagram showing the function of an interpreter.

- **Syntax:** The set of rules that govern the structure and format of statements in a programming language. Like grammar in human languages, correct syntax is essential for the program to be understood by the translator.
 - ✓ **Example (Python Syntax):** Using indentation to define code blocks.
- **Source Code:** The text written by a programmer in a programming language, which contains the instructions for the computer to execute.
 - ✓ **Image:** (Refer to the simple Python program example above)
- **Machine Code:** The lowest-level form of computer instructions, represented in binary code (sequences of 0s and 1s), that the CPU can directly execute. It is specific to the architecture of the computer's processor.
 - ✓ **Example (Simplified Machine Code):** 00101011 00011100 (representing an instruction).

* **Integrated Development Environment (IDE):** A software application that provides comprehensive facilities to computer programmers for software development. An IDE typically includes a source code editor, a compiler or interpreter, build automation tools, and a debugger. Examples include PyCharm, Eclipse, and Visual Studio.

Software Development Life Cycle (SDLC): A structured process followed by software development teams to design, develop, test, and deploy software applications. It typically includes stages like planning, analysis, design, implementation, testing, deployment, and maintenance.

3.1.2 Evolution of Programming Languages

(b) Describe the Evolution of Programming Languages in Software Development:

The evolution of programming languages has been driven by the need for more efficient, easier-to-use, and powerful ways to instruct computers.

- **First Generation (Machine Language):** The earliest programming involved writing instructions directly in binary code (0s and 1s) that the computer's CPU could understand. This was tedious, error-prone, and machine-dependent.
 - ✓ **Timeline:** Late 1940s and early 1950s.
 - ✓ **Characteristics:** Directly executed by the CPU, machine-specific, difficult for humans to read and write.
 - ✓ **Example:** Sequences of binary digits representing operations and memory addresses.
- **Second Generation (Assembly Language):** To make programming easier, symbolic codes (mnemonics) were introduced to represent machine instructions. An assembler was needed to translate assembly language into machine code. Still low-level and machine-dependent but more human-readable.
 - ✓ **Timeline:** 1950s.
 - ✓ **Characteristics:** Uses mnemonics (e.g., ADD, SUB, MOV), requires an assembler, machine-specific, more manageable than machine code.
 - ✓ **Example:** ADD A, B (add the value in register B to register A).
- **Third Generation (High-Level Languages):** These languages were designed to be more human-like, abstracting away many of the low-level details of the computer's architecture. They require compilers or interpreters to be translated into machine code. Examples include FORTRAN, COBOL, BASIC, Pascal, and C.

- ✓ **Timeline:** 1950s to 1970s.
- ✓ **Characteristics:** More English-like syntax, easier to read and write, machine-independent (portable to different architectures with recompilation), requires compilers or interpreters.
- ✓ **Example (FORTRAN):** `DO 10 I = 1, 10`
- ✓ **Example (BASIC):** `10 PRINT "Hello"`
- **Fourth Generation (Very High-Level Languages):** These languages are designed to be even more user-friendly and often focus on specific types of applications, such as database management and report generation. They often use less code to accomplish more than third-generation languages. Examples include SQL, and scripting languages like Perl and early versions of Python.
 - ✓ **Timeline:** 1970s to 1990s.
 - ✓ **Characteristics:** More abstract than 3GLs, often application-specific, may use visual programming environments, focus on productivity.
 - ✓ **Example (SQL):** `SELECT * FROM users WHERE age > 30;`
- **Fifth Generation (Declarative Languages and AI Programming):** These languages are often based on artificial intelligence principles, aiming to solve problems using constraints and rules rather than explicit algorithms. Examples include Prolog and Lisp (though Lisp has roots in earlier generations). Also includes visual programming and natural language processing.
 - ✓ **Timeline:** 1980s to present.
 - ✓ **Characteristics:** Focus on "what" needs to be done rather than "how," used in AI, expert systems, and logic programming.
 - ✓ **Example (Prolog):** `parent(john, mary).`

3.1.3 Categorisation of Programming Languages by Paradigms

(c) Categorise the Programming Languages According to the Paradigms:

A programming paradigm is a style or approach to programming. Languages can support multiple paradigms.

- **Structured Programming:** A paradigm that emphasizes the use of structured control flow constructs like sequences, selections (if-then-else), and iterations (loops) to create well-organized and easy-to-understand programs. Procedural programming is often considered a type of structured programming.
 - ✓ **Languages:** Pascal, C, early versions of BASIC.
- **Procedural Programming:** A paradigm where the program is organized into a set of procedures (also called functions or subroutines) that perform specific tasks. Execution involves calling these procedures in a specific order.
 - ✓ **Languages:** C, Pascal, FORTRAN.
- **Object-Oriented Programming (OOP):** A paradigm based on the concept of "objects," which are instances of "classes." Objects encapsulate data (attributes) and the code that operates on that data (methods). Key principles of OOP include encapsulation, inheritance, and polymorphism.
 - ✓ **Languages:** Java, Python, C++, C#, Smalltalk.
- **Functional Programming:** A paradigm that treats computation as the evaluation of mathematical functions and avoids changing state and mutable data. Emphasizes immutability and side-effect-free functions.
 - ✓ **Languages:** Haskell, Lisp, Clojure, F#, and functional features in Python and JavaScript.
- **Logic Programming:** A paradigm based on formal logic. Programs are expressed as a set of logical sentences (facts and rules), and computation is performed by making logical inferences.
 - ✓ **Languages:** Prolog.

- **Event-Driven Programming:** A paradigm where the flow of the program is determined by events such as user actions (mouse clicks, key presses), sensor outputs, or messages from other programs. Common in GUI applications.
 - ✓ **Languages:** JavaScript (for web), C# (for Windows Forms), Python (with libraries like Tkinter or PyQt).

3.1.4 Simulating Low-Level Programming Languages

(d) Create Simple Instructions to Simulate Low-Level Programming Languages:

Simulating machine language and assembly language can be done by creating a simplified model of a CPU with registers and a small set of instructions.

Simplified Machine Language Simulation:

Let's assume a very simple CPU with two registers (R1 and R2) and a small instruction set:

```
0001: LOAD value into a register (e.g., 0001 01 10 - LOAD 10 into R1)
0010: ADD the values of two registers (e.g., 0010 01 10 - ADD R1 and R2, store in R1)
0011: STORE the value of a register to memory (we'll skip memory addressing for simplicity)
0100: HALT (end program)
```

A sequence of machine code instructions might look like:

```
0001 01 05 // LOAD 5 into R1
0001 10 03 // LOAD 3 into R2
0010 01 10 // ADD R1 and R2 (result in R1)
0011 01    // STORE R1 (in a conceptual output)
0100 00    // HALT
```

Simplified Assembly Language Simulation:

We can use mnemonics for the above machine code:

```
LOAD R1, 5
LOAD R2, 3
ADD R1, R2 (assuming result goes to the first operand)
STORE R1
HALT
```

To simulate this, one could manually trace the execution:

1. `LOAD R1, 5`: Register R1 now holds the value 5.
2. `LOAD R2, 3`: Register R2 now holds the value 3.
3. `ADD R1, R2`: The value of R2 (3) is added to the value of R1 (5), and the result (8) is stored in R1. R1 is now 8, R2 is 3.
4. `STORE R1`: The value of R1 (8) is conceptually stored or displayed as output.
5. `HALT`: The program ends.

This simple simulation demonstrates the basic operation of low-level instructions involving registers and operations.

3.1.5 Acknowledging the Evolution of Programming Languages

(e) Acknowledge the Evolution of Programming Languages in Software Development:

The evolution of programming languages represents a significant advancement in the field of computer science. This evolution has led to:

- ✓ **Increased Programmer Productivity:** Higher-level languages allow programmers to write more complex programs with less code, saving time and effort.
- ✓ **Improved Code Readability and Maintainability:** More human-like syntax makes code easier to understand, debug, and maintain over time.
- ✓ **Greater Portability:** High-level languages can be compiled or interpreted to run on different computer architectures, increasing software portability.
- ✓ **Abstraction of Complexity:** Programmers can focus on solving the problem at hand rather than dealing with the intricacies of the underlying hardware.
- ✓ **Development of New Paradigms:** The evolution has introduced new ways of thinking about and structuring programs, leading to more powerful and flexible software development approaches (like OOP and functional programming).
- ✓ **Democratization of Programming:** Higher-level languages and better development tools have made programming accessible to a wider range of people.

3.1.6 Why Programming Languages are Important in Computing

Programming languages are fundamental to computing because they:

- ✓ **Enable Communication with Computers:** They provide a way for humans to give instructions to computers in a structured and understandable format.
- ✓ **Drive Software Development:** All software applications, from operating systems to mobile apps, are created using programming languages.
- ✓ **Automate Tasks:** Programming allows for the automation of repetitive and complex tasks, increasing efficiency and reducing errors.
- ✓ **Solve Problems:** They provide the tools to create algorithms and implement solutions to a wide range of problems in various domains.
- ✓ **Control Hardware:** Programming is used to write firmware and drivers that control the behavior of computer hardware.
- ✓ **Facilitate Innovation:** They are essential for developing new technologies and pushing the boundaries of what computers can do.

- ✓ **Support Data Processing and Analysis:** Programming languages are crucial for manipulating, analyzing, and extracting insights from data.
- ✓ **Power the Digital World:** From the internet to artificial intelligence, programming languages are the backbone of the digital infrastructure that shapes modern society.

3.1.7 How Programming Languages are Executed

Programming languages are executed through the process of translation into machine code that the CPU can understand and execute. The method of translation depends on the type of language:

- ✓ **Compiled Languages:** The entire source code is first translated into machine code (or an intermediate code) by a compiler. This translation process happens once. The resulting executable code can then be run directly by the computer's CPU (or a virtual machine for intermediate code like Java bytecode). Execution is generally faster after compilation. Examples: C, C++, Java (to bytecode).
- ✓ **Interpreted Languages:** The source code is translated and executed line by line by an interpreter each time the program is run. No separate executable file is created. This allows for easier debugging and cross-platform compatibility (if an interpreter exists for the target platform). Execution can be slower than compiled code. Examples: Python, JavaScript, Ruby.
- ✓ **Assembly Language:** Translated into machine code by an assembler. Each assembly instruction typically corresponds directly to one machine instruction. The resulting machine code is then executed directly by the CPU.

SUB-STRAND 3.2: PROGRAM DEVELOPMENT (15 Lessons)

3.2.1 Stages of Program Development

(a) Describe Stages of Program Development in Computer Programming:

The program development cycle (PDC) is a series of steps that software developers typically follow to create a computer program. These stages help to organize the development process and ensure that the final product meets the required specifications.

- ✓ **Problem Definition:** Clearly understanding and defining the problem that the program needs to solve. This involves identifying the inputs, the desired outputs, and any constraints or requirements.
 - **Example:** The problem is to create a program that calculates the area of a rectangle given its length and width.
- ✓ **Program Design:** Planning the solution to the defined problem. This stage involves designing the algorithm (a step-by-step procedure) that the program will follow. Tools like pseudocode and flowcharts are used to represent the algorithm's logic.
 - **Example:** Designing an algorithm that takes length and width as input, multiplies them, and displays the result as the area.
- ✓ **Coding (Implementation):** Translating the designed algorithm into a specific programming language. This involves writing the actual source code of the program.
 - **Example:** Writing the program in Python using input functions, arithmetic operations, and output functions.

- ✓ **Testing:** Checking if the program works correctly and meets the requirements defined in the problem definition. This involves running the program with various inputs to identify and fix any errors (bugs). Different types of testing include unit testing, integration testing, and system testing.
 - **Example:** Running the area calculation program with different length and width values to ensure it produces the correct area. Testing with invalid inputs (e.g., negative numbers) might also be necessary.
- ✓ **Implementation (Deployment):** Making the program available for use. This might involve installing the program on users' computers, deploying it on a server, or making it accessible through a web browser.
 - **Example:** Distributing the compiled program or deploying a web application that calculates the rectangle's area.
- ✓ **Documentation:** Creating written materials that describe the program, its design, how to use it, and its development process. This includes user manuals, technical documentation, and comments within the source code.
 - **Example:** Writing a user guide explaining how to input the length and width and interpret the output of the area calculation program.
- ✓ **Maintenance:** Modifying, updating, and fixing errors in the program after it has been deployed. This can include bug fixes, performance improvements, and adding new features.
 - **Example:** Updating the area calculation program to handle different units of measurement or to calculate the perimeter as well.

(b) Write a Pseudocode to Illustrate the Logical Flow of an Algorithm:

Pseudocode is an informal, high-level description of the operating principle of a computer program or other algorithm. It uses structural conventions of a normal programming language but is intended for human reading rather than machine reading. It typically omits details like variable declarations and specific syntax.

Keywords Commonly Used in Pseudocode:

START / BEGIN: Marks the beginning of the algorithm.

INPUT: Indicates that data is to be received from the user or an external source.

OUTPUT / PRINT / DISPLAY: Indicates that data is to be shown to the user or sent to an external destination.

SET / LET: Assigns a value to a variable.

IF ... THEN ... ELSE ... ENDIF: Represents a decision or conditional statement.

WHILE ... DO ... ENDWHILE: Represents a loop that continues as long as a condition is true.

FOR ... TO ... STEP ... ENDFOR: Represents a loop that iterates a specific number of times.

Mathematical operators (+, -, *, /, ^, MOD) and comparison operators (=, <, >, <=, >=, !=).

END / STOP: Marks the end of the algorithm.

Variables are used to store data.

Example Pseudocode (Calculate Area of a Rectangle):

```
START
  INPUT length
  INPUT width
  SET area = length * width
  OUTPUT area
END
```

Example Pseudocode (Find the Larger of Two Numbers):

```
START
  INPUT number1
  INPUT number2
  IF number1 > number2 THEN
    OUTPUT number1
  ELSE
    OUTPUT number2
  ENDIF
END
```

Example Pseudocode (Calculate Sum of Numbers from 1 to N):

```
START
  INPUT N
  SET sum = 0
  SET counter = 1
  WHILE counter <= N DO
    SET sum = sum + counter
    SET counter = counter + 1
  ENDWHILE
  OUTPUT sum
END
```

(c) Represent the Logical Flow of an Algorithm Using a Flowchart:

A flowchart is a diagram that uses standard symbols to represent the steps and decisions in an algorithm. It provides a visual representation of the logical flow of the program.

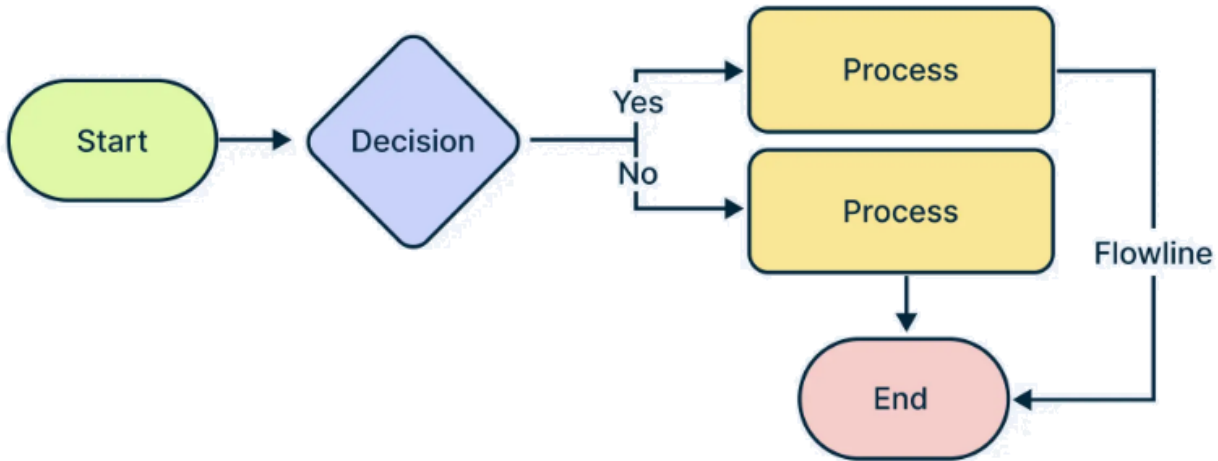

Standard Flowchart Symbols:

- **Terminal (Start/End):** Represented by an oval or rounded rectangle. Indicates the beginning and end of the algorithm.

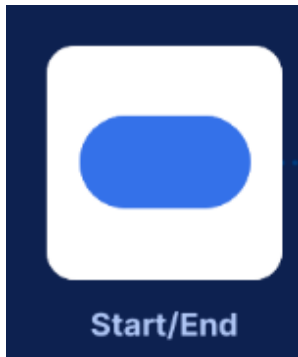

- **Process:** Represented by a rectangle. Indicates an operation or a step in the algorithm (e.g., calculation, assignment).

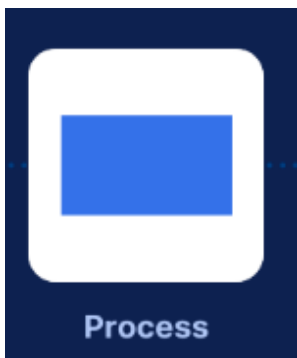

- **Input/Output:** Represented by a parallelogram. Indicates data being read from an input source or written to an output destination.



- **Decision:** Represented by a diamond. Indicates a point where a condition is evaluated, and the flow of the algorithm branches based on the outcome (True or False, Yes or No).

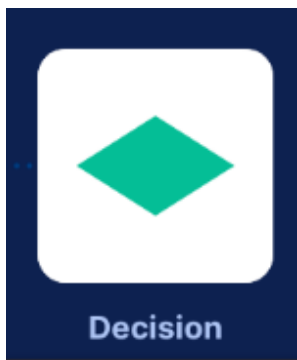

- **Flow Lines (Arrows):** Represented by arrows. Show the direction of flow of control in the algorithm.



- **Connector (On-page):** Represented by a small circle. Used to connect different parts of the flowchart on the same page, avoiding long or crossing flow lines.
 - **Symbol:** (○)
- **Off-page Connector:** Represented by a pentagon or a shaped rectangle. Used to connect different parts of the flowchart across multiple pages.

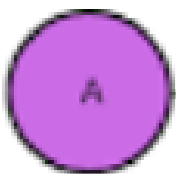

Example Flowchart (Calculate Area of a Rectangle):

Code snippet

```
graph TD
  A(Start) --> B{Input Length};
  B --> C{Input Width};
  C --> D[Area = Length * Width];
  D --> E{Output Area};
  E --> F(End);
```

Example Flowchart (Find the Larger of Two Numbers):

Code snippet

```
graph TD
  A(Start) --> B{Input Number1};
  B --> C{Input Number2};
  C --> D{Number1 > Number2?};
  D -- Yes --> E{Output Number1};
  D -- No --> F{Output Number2};
  E --> G(End);
  F --> G;
```

Example Flowchart (Calculate Sum of Numbers from 1 to N):

Code snippet

```
graph TD
  A(Start) --> B{Input N};
  B --> C[Sum = 0];
  C --> D[Counter = 1];
  E{Counter <= N?};
  D --> E;
  E -- Yes --> F[Sum = Sum + Counter];
  F --> G[Counter = Counter + 1];
  G --> E;
  E -- No --> H{Output Sum};
  H --> I(End);
```

(d) Design an Algorithm to Solve a Real-Life Problem:

Designing an algorithm involves breaking down a problem into a sequence of steps that can be followed to achieve the desired outcome.

Example Real-Life Problem: Algorithm to Prepare a Cup of Tea:

1. **Start**
2. **Input:** Get a kettle, water, tea bag, cup, and optionally sugar and milk.
3. Fill the kettle with water.
4. Turn on the kettle and wait for the water to boil.
5. Pour the boiled water into the cup.
6. Place the tea bag in the cup of hot water.
7. Wait for the tea to brew (e.g., 2-3 minutes).
8. Remove the tea bag from the cup.
9. **Decision:** If the user wants sugar, then add sugar to the cup and stir.

10. **Decision:** If the user wants milk, then add milk to the cup and stir.
11. **Output:** Serve the cup of tea.
12. **End**

Pseudocode for Preparing Tea:

```

START
  INPUT kettle, water, teaBag, cup, sugar (optional), milk (optional)
  FILL kettle WITH water
  TURN_ON kettle
  WAIT_UNTIL water BOILS
  POUR boiled_water INTO cup
  PLACE teaBag IN cup
  WAIT FOR 180 SECONDS (3 minutes)
  REMOVE teaBag FROM cup
  INPUT wantsSugar
  IF wantsSugar IS TRUE THEN
    INPUT amountOfSugar
    ADD amountOfSugar TO cup
    STIR
  ENDIF
  INPUT wantsMilk
  IF wantsMilk IS TRUE THEN
    INPUT amountOfMilk
    ADD amountOfMilk TO cup
    STIR
  ENDIF
  OUTPUT cup OF tea
END

```

Flowchart for Preparing Tea (Simplified):

Code snippet

```

graph TD
  A(Start) --> B(Get Kettle, Water, Tea Bag, Cup);
  B --> C(Fill Kettle with Water);
  C --> D(Turn on Kettle);
  D --> E{Water Boils?};
  E -- No --> D;
  E -- Yes --> F(Pour Water into Cup);
  F --> G(Place Tea Bag in Cup);
  G --> H(Wait 3 Minutes);
  H --> I(Remove Tea Bag);
  I --> J{Wants Sugar?};
  J -- Yes --> K(Add Sugar, Stir);
  J -- No --> L{Wants Milk?};
  K --> L;
  L -- Yes --> M(Add Milk, Stir);
  L -- No --> N(Serve Tea);
  M --> N;
  N --> O(End);

```

(e) Appreciate the Importance of Using Algorithms in Problem Solving:

Algorithms are fundamental to computer science and problem-solving for several reasons:

- **Logical Structure:** They provide a clear and logical sequence of steps to solve a problem, making the solution easier to understand and implement.
- **Efficiency:** Designing efficient algorithms can significantly reduce the time and resources required to solve a problem.
- **Automation:** Once an algorithm is developed, it can be translated into a computer program to automate the problem-solving process.
- **Reproducibility:** Algorithms ensure that the same input will always produce the same output, making the solution consistent and reliable.
- **Communication:** Flowcharts and pseudocode provide a way to communicate the solution to others, regardless of the programming language being used.
- **Foundation for Programming:** Algorithms are the blueprint for writing computer code. Without a well-defined algorithm, the coding process can be chaotic and error-prone.
- **Problem Decomposition:** Complex problems can be broken down into smaller, more manageable sub-problems, each with its own algorithm, making the overall problem easier to solve.

SUB-STRAND 3.3: IDENTIFIERS AND OPERATORS

3.3.1 Elementary Elements of a Computer Program

(a) Describe the Elementary Elements of a Computer Program:

A computer program is made up of several fundamental elements that work together to perform a specific task. These include:

- **Structure:** Refers to the way the program is organized and how its different parts are related. Structured programming emphasizes a logical flow using constructs like sequences, selections (if-else), and iterations (loops). This makes programs easier to read, understand, and maintain.
 - ✓ **Example (Python - Sequence):**

Python

```
print("Step 1")
print("Step 2")
print("Step 3")
```

- ✓ **Example (Python - Selection):**

Python

```
age = 20
if age >= 18:
    print("Adult")
else:
    print("Minor")
```

- ✓ **Example (Python - Iteration):**

Python

```
for i in range(5):  
    print(i)
```

- **Syntax:** The set of rules that dictate the correct way to write statements in a programming language. Just like grammar in human languages, following the syntax is crucial for the compiler or interpreter to understand the code. Syntax errors will prevent the program from running.
 - ✓ **Example (Syntax Error in Python):** Missing a colon after an `if` statement will result in a syntax error.

Python

```
if age >= 18 # Missing colon  
    print("Adult")
```

- **Errors:** Issues that can occur in a program. There are different types:
 - ✓ **Syntax Errors:** Violations of the programming language's grammar rules. Detected by the compiler or interpreter before or during execution.
 - ✓ **Logical Errors:** Errors in the program's design or algorithm that cause it to produce incorrect results, even if the syntax is correct. These are often harder to find and require careful testing.
 - ✓ **Runtime Errors:** Errors that occur while the program is running. These can be due to issues like division by zero, trying to access an invalid memory location, or attempting an operation that is not allowed.
- **Reserved Words (Keywords):** Words that have a predefined meaning in a programming language and cannot be used as identifiers (e.g., `if`, `else`, `for`, `while`, `print`, `class`, `def`).
 - ✓ **Example (Python Keywords):** `and`, `as`, `assert`, `break`, `class`, `continue`, `def`, `del`, `elif`, `else`, `except`, `False`, `finally`, `for`, `from`, `global`, `if`, `import`, `in`, `is`, `lambda`, `None`, `nonlocal`, `not`, `or`, `pass`, `raise`, `return`, `True`, `try`, `while`, `with`, `yield`.
- **Identifiers:** Names given to variables, constants, functions, classes, and other user-defined entities in a program. They allow programmers to refer to these elements. Most languages have rules for naming identifiers (e.g., must start with a letter or underscore, cannot contain spaces or special characters, case sensitivity).
 - ✓ **Example (Valid Python Identifiers):** `age`, `student_name`, `totalAmount`, `calculate_area`.
 - ✓ **Example (Invalid Python Identifiers):** `1st_name`, `student name`, `total-amount`, `if`.
- **Data Types:** Classifications of data that determine the possible values, the operations that can be performed on them, and the way they are stored in memory. Common data types include integers, floating-point numbers, strings, booleans, etc.
 - ✓ **Example (Common Data Types):**
 - **Integer:** Whole numbers (e.g., `10`, `-5`).
 - **Float:** Numbers with decimal points (e.g., `3.14`, `-2.5`).
 - **String:** Sequences of characters (e.g., `"Hello"`, `"World"`).
 - **Boolean:** Logical values (e.g., `True`, `False`).
- **Standard Libraries:** Collections of pre-written code (functions, modules, classes) that provide ready-to-use functionalities for common tasks, saving programmers from having to write everything from scratch.
 - ✓ **Example (Python Standard Library):** The `math` module provides mathematical functions (e.g., `math.sqrt()`, `math.sin()`), and the `os` module provides operating system-related functions.

3.3.2 Variables and Constants

(b) Declare Variables and Constants in a Programming Language:

Variables are named storage locations in memory that hold data values that can change during the execution of a program. Constants are named storage locations whose values are set once and cannot be changed during program execution.

The syntax for declaring variables and constants varies between programming languages.

- **Variable Declaration (Examples):**

- ✚ **Python (Dynamically Typed):** You typically don't explicitly declare the data type. It's inferred at the time of assignment.

Python

```
age = 25
name = "Alice"
is_student = True
```

- ✚ **C++ (Statically Typed):** You need to specify the data type when declaring a variable.

C++

```
int age = 25;
std::string name = "Alice";
bool isStudent = true;
```

- ✚ **Java (Statically Typed):** Similar to C++.

Java

```
int age = 25;
String name = "Alice";
boolean isStudent = true;
```

- **Constant Declaration (Examples):**

- ✚ **Python:** Python doesn't have a built-in way to enforce true constants. By convention, variables intended as constants are often named in all uppercase.

Python

```
PI = 3.14159
MAX_USERS = 100
```

- ✚ **C++:** Uses the `const` keyword to declare constants.

C++

```
const double PI = 3.14159;
const int MAX_USERS = 100;
```

- ✚ **Java:** Uses the `final` keyword to declare constants (often also `static` for class constants).

Java

```
final double PI = 3.14159;
static final int MAX_USERS = 100;
```

- **Assigning Data Types to Variables:** In statically typed languages (like C++, Java), the data type is explicitly assigned during declaration and cannot typically be changed later. In dynamically typed languages (like Python), the data type of a variable can change as different values are assigned to it.

- ✚ **Example (Python - Dynamic Typing):**

Python

```
x = 10          # x is an integer
print(type(x))
x = "Hello"    # x is now a string
print(type(x))
```

3.3.3 Input and Output Statements

(c) Use Input and Output Statements in a Programming Language:

Input statements allow a program to receive data from an external source, typically the user (via the keyboard).

Output statements allow a program to display or send data to an external destination, typically the console (screen).

- **Input Statements (Examples):**

- ✚ **Python:** The `input()` function is used to get input from the user. It returns a string, which may need to be converted to other data types.

Python

```
name = input("Enter your name: ")
age_str = input("Enter your age: ")
age = int(age_str) # Convert string to integer
```

- ✚ **C++:** The `std::cin` object (from the `<iostream>` library) is used for input.

C++

```
std::string name;
int age;
std::cout << "Enter your name: ";
std::cin >> name;
std::cout << "Enter your age: ";
std::cin >> age;
```

- ✚ **Java:** The `Scanner` class (from the `java.util` package) is commonly used for input.

Java

```
import java.util.Scanner;

Scanner scanner = new Scanner(System.in);
System.out.print("Enter your name: ");
String name = scanner.nextLine();
System.out.print("Enter your age: ");
int age = scanner.nextInt();
scanner.close();
```

- **Output Statements (Examples):**

- ✚ **Python:** The `print()` function is used to display output to the console.

Python

```
name = "Bob"
age = 30
print("Name:", name)
print(f"Age: {age}") # f-string formatting
```

- ✚ **C++:** The `std::cout` object (from the `<iostream>` library) is used for output.

C++

```
std::string name = "Bob";
int age = 30;
std::cout << "Name: " << name << std::endl;
std::cout << "Age: " << age << std::endl;
```

- ✚ **Java:** The `System.out.println()` method is used for output to the console (with a newline at the end), and `System.out.print()` for output without a newline.

Java

```
String name = "Bob";
int age = 30;
System.out.println("Name: " + name);
System.out.println("Age: " + age);
```

3.3.4 Operators in a Programming Language

(d) Use Operators in a Programming Language:

Operators are special symbols that perform operations on one or more operands (values or variables). Programming languages typically provide various categories of operators:

- ✓ **Arithmetic Operators:** Used to perform mathematical calculations.

- ❖ + (Addition)
- ❖ - (Subtraction)
- ❖ * (Multiplication)
- ❖ / (Division)
- ❖ // (Floor Division - integer part of the division)
- ❖ % (Modulo - remainder of the division)
- ❖ ** (Exponentiation - raising to a power)

- **Example (Python):**

Python

```
a = 10
b = 3
print(a + b)    # 13
print(a - b)    # 7
print(a * b)    # 30
print(a / b)    # 3.333...
print(a // b)   # 3
print(a % b)    # 1
print(a ** b)   # 1000
```

✓ **Assignment Operators:** Used to assign values to variables.

- ❖ = (Simple assignment)
- ❖ += (Add and assign)
- ❖ -= (Subtract and assign)
- ❖ *= (Multiply and assign)
- ❖ /= (Divide and assign)
- ❖ //= (Floor divide and assign)
- ❖ %= (Modulo and assign)
- ❖ **= (Exponentiate and assign)

- **Example (Python):**

Python

```
x = 5
x += 2    # x = x + 2 (x becomes 7)
y = 10
y %= 3    # y = y % 3 (y becomes 1)
```

✓ **Increment and Decrement Operators:** Used to increase or decrease the value of a variable by one (common in languages like C++, Java). Python uses += 1 and -= 1 for this.

- ❖ ++ (Increment)
- ❖ -- (Decrement)

- **Example (C++):**

C++

```
int count = 0;
```

```

count++; // count becomes 1
int num = 5;
num--; // num becomes 4

```

- ✓ **Relational (Comparison) Operators:** Used to compare two values. They return a boolean result (True or False).

- ❖ == (Equal to)
- ❖ != (Not equal to)
- ❖ > (Greater than)
- ❖ < (Less than)
- ❖ >= (Greater than or equal to)
- ❖ <= (Less than or equal to)

- **Example (Python):**

Python

```

p = 5
q = 10
print(p == q) # False
print(p != q) # True
print(p < q)  # True

```

- ✓ **Logical Operators:** Used to combine or modify boolean expressions.

- ❖ and (Logical AND - true if both operands are true)
- ❖ or (Logical OR - true if at least one operand is true)
- ❖ not (Logical NOT - true if the operand is false)

- **Example (Python):**

Python

```

age = 25
is_student = True
if age > 18 and is_student:
    print("Eligible")
if age < 18 or is_student:
    print("Young or a student")
if not is_student:
    print("Not a student")

```

- ✓ **Order of Precedence:** Operators have a specific order in which they are evaluated in an expression. For example, multiplication and division usually have higher precedence than addition and subtraction. Parentheses can be used to override the default precedence.

- ❖ **Example (Python):**

Python

```

result = 5 + 3 * 2 # Multiplication is done first (result is 11)
result = (5 + 3) * 2 # Parentheses force addition first (result is 16)

```

3.3.5 Appreciation of Identifiers and Operators

(e) Appreciate the Role of Identifiers and Operators in Programming:

Identifiers and operators are fundamental building blocks of any computer program. Their roles are crucial for the following reasons:

- ✓ **Identifiers Enable Data Management:** They provide a way to name and refer to memory locations (variables and constants) where data is stored. This allows programs to store, retrieve, and manipulate information effectively. Meaningful identifiers make code more readable and understandable.
- ✓ **Operators Facilitate Computation and Logic:** Operators allow programs to perform calculations (arithmetic operators), assign values (assignment operators), compare data (relational operators), and make logical decisions (logical operators). They are the verbs of a programming language, enabling the program to perform actions and make choices.
- ✓ **Structure and Control Flow:** Operators, especially relational and logical ones, are essential for creating control flow structures (like `if` statements and loops) that determine the order in which instructions are executed based on certain conditions.
- ✓ **Expressing Algorithms:** Algorithms, the step-by-step solutions to problems, are implemented in programming languages using identifiers to represent data and operators to perform the necessary operations.
- ✓ **Interacting with the User:** Identifiers are used to store input received from the user, and operators are used to process this input and generate meaningful output.
- ✓ **Using Libraries:** Identifiers are used to refer to functions, classes, and modules from standard and third-party libraries, extending the capabilities of the program. Operators are used to interact with these library components.

Without identifiers, programs would not be able to store and manage data. Without operators, programs would be limited to static sequences of instructions without the ability to perform calculations, comparisons, or make decisions. Together, identifiers and operators provide the essential tools for programmers to create dynamic, functional, and problem-solving software.

3.3.6 Importance of Structured Programming Language

(Key Inquiry Question 1: What is the importance of structured programming language?)

Structured programming languages (which enforce or encourage structured programming principles) are important because they:

- ✓ **Improve Code Readability:** The use of clear control flow structures (sequence, selection, iteration) makes the program's logic easier to follow.
- ✓ **Enhance Code Maintainability:** Well-structured code is easier to understand, debug, and modify, reducing the effort required for maintenance.
- ✓ **Reduce Complexity:** By breaking down programs into smaller, logical blocks, structured programming helps manage the complexity of large software projects.
- ✓ **Promote Code Reusability:** Procedures and functions, key elements of structured programming, can be reused in different parts of the program or in other programs.

- ✓ **Facilitate Teamwork:** A consistent and structured approach makes it easier for multiple programmers to work on the same project.
- ✓ **Minimize Errors:** The clear and logical flow of control reduces the likelihood of logical errors and makes them easier to identify during testing.
- ✓ **Improve Efficiency:** While not always directly related to performance, structured programming can lead to more efficient algorithms due to better organization.

3.3.7 How Variables are Declared in Programming Languages

The way variables are declared varies depending on whether the language is statically typed or dynamically typed:

- **Statically Typed Languages (e.g., C++, Java, C#):**
 - Variables must be explicitly declared before they can

SUB-STRAND 3.4: CONTROL STRUCTURES (17 Lessons)

3.4.1 Introduction to Control Structures

(a) Describe Control Structures and their Importance in Programming:

Control structures are statements in a programming language that determine the flow of execution of instructions in a program. They allow a program to make decisions, repeat blocks of code, and execute instructions in a specific order. The three basic types of control structures are:

- ✚ **Sequential Control Structure:** Instructions are executed in the order they appear in the program, one after the other, from top to bottom. This is the default way code is executed.
 - ✓ **Example (Python):**

Python

```
print("Start")
x = 5
y = 10
sum = x + y
print("The sum is:", sum)
print("End")
```

In this example, each `print` and assignment statement is executed in the order it is written.

- ✚ **Selection (Conditional) Control Structure:** Allows the program to make decisions and execute different blocks of code based on whether a certain condition is true or false. Common selection structures include `if`, `if-else`, and `if-elif-else` statements.
 - ✓ **Example (Python - `if`):**

Python

```
age = 18
```

```
if age >= 18:
    print("You are eligible to vote.")
```

The `print` statement is executed only if the condition `age >= 18` is true.

✓ **Example (Python - if-else):**

Python

```
number = 10
if number % 2 == 0:
    print("The number is even.")
else:
    print("The number is odd.")
```

One of the two `print` statements is executed based on whether the condition `number % 2 == 0` is true or false.

✓ **Example (Python - if-elif-else):**

Python

```
score = 75
if score >= 80:
    grade = "A"
elif score >= 70:
    grade = "B"
elif score >= 60:
    grade = "C"
else:
    grade = "Fail"
print("Your grade is:", grade)
```

One of the grade assignments is executed based on the value of `score`.

✚ **Iteration (Looping) Control Structure:** Allows a block of code to be executed repeatedly, either a specific number of times or as long as a certain condition is true. Common iteration structures include `for` and `while` loops.

✓ **Example (Python - for loop):**

Python

```
for i in range(5):
    print("Iteration:", i)
```

The `print` statement is executed 5 times, with the value of `i` changing in each iteration.

✓ **Example (Python - while loop):**

Python

```
count = 0
while count < 3:
    print("Count is:", count)
    count += 1
```

The `print` and `count += 1` statements are executed repeatedly as long as the condition `count < 3` is true.

Importance of Control Structures:

Control structures are fundamental to programming because they enable:

- **Decision Making:** Allowing programs to respond differently to different inputs or conditions.
- **Repetitive Tasks:** Automating tasks that need to be performed multiple times.
- **Logical Flow:** Structuring the execution of code in a clear and organized manner.
- **Algorithm Implementation:** Translating algorithms into executable programs.
- **Problem Solving:** Creating complex and sophisticated solutions to real-world problems.
- **Flexibility and Dynamism:** Making programs more versatile and able to handle various scenarios.

Without control structures, programs would only be able to execute a fixed sequence of instructions, limiting their ability to solve complex problems or interact dynamically with users or data.

3.4.2 Selecting Appropriate Program Control Structures

(b) Select Appropriate Program Control Structure for a Given Situation:

Choosing the right control structure depends on the specific task or logic that needs to be implemented.

- **Sequential:** Use when instructions need to be executed in a linear order without any branching or repetition.
 - ✓ **Example:** A simple script to calculate the average of three fixed numbers.
- **Selection (`if`, `if-else`, `if-elif-else`):** Use when the program needs to perform different actions based on whether a condition is true or false.
 - ✓ **`if`:** To execute a block of code only if a condition is true.
 - **Example:** Displaying a warning message if a temperature exceeds a certain threshold.
 - ✓ **`if-else`:** To execute one block of code if a condition is true and another block if it is false.
 - **Example:** Checking if a user's password is correct and displaying either a success or failure message.
 - ✓ **`if-elif-else`:** To check multiple conditions in sequence and execute the block of code corresponding to the first true condition. The `else` block (optional) is executed if none of the conditions are true.
 - **Example:** Assigning grades based on different score ranges.
- **Iteration (`for`, `while`):** Use when a block of code needs to be executed repeatedly.
 - ✓ **`for loop`:** Typically used when the number of iterations is known beforehand or when iterating over a sequence (like a list or range).
 - **Example:** Printing the numbers from 1 to 10.

- **Example:** Processing each item in a list of student names.
- ✓ **while loop:** Used when the number of iterations is not known beforehand and the loop continues as long as a certain condition remains true. It's crucial to ensure that the condition eventually becomes false to avoid an infinite loop.
 - **Example:** Reading user input until a specific value is entered.
 - **Example:** Simulating a process that continues until a certain state is reached.

Examples of Selecting Control Structures for Situations:

- ✓ **Calculating the factorial of a number:** A `for` loop (if iterating from 1 to the number) or a `while` loop (if decrementing the number until 1) would be appropriate for the repeated multiplication.
- ✓ **Validating user input (e.g., ensuring an age is not negative):** An `if` statement to check the condition and potentially a `while` loop to keep prompting the user until valid input is provided.
- ✓ **Displaying a menu of options to the user and performing an action based on their choice:** An `if-elif-else` structure or a `switch` statement (if available in the language) would be suitable. A `while` loop might be used to keep displaying the menu until the user chooses to exit.
- ✓ **Processing all the records in a database:** A loop (e.g., `for` loop iterating through the results of a query or a `while` loop reading records one by one) would be necessary.

3.4.3 Using Control Structures in Programming

(c) Use Control Structures in Programming:

This involves writing actual code in a chosen programming language that implements the sequential, selection, and iteration control structures. The specific syntax will vary depending on the language (e.g., Python, Java, C++).

Python Examples:

- ✓ **Sequential:** (Already shown in 3.4.1)
- ✓ **Selection:** (Already shown in 3.4.1)
- ✓ **Iteration:** (Already shown in 3.4.1)

Break and Continue Statements:

Within loops, `break` and `continue` statements can be used to alter the normal flow of execution:

- ✓ **break statement:** Immediately terminates the innermost loop it is contained within. Execution continues with the statement immediately following the loop.

Python

```
for i in range(10):
    if i == 5:
        break
    print(i) # Output: 0 1 2 3 4
print("Loop finished")
```

- ✓ **continue statement:** Skips the rest of the current iteration of the loop and proceeds to the next iteration.

Python

```
for i in range(5):  
    if i == 3:  
        continue  
    print(i) # Output: 0 1 2 4
```

Writing and Executing Programs:

This step involves using a text editor or an Integrated Development Environment (IDE) to write the code containing control structures and then using the appropriate compiler or interpreter to run the program and observe its behavior.

3.4.4 Appreciation of the Application of Control Structures

(d) Appreciate the Application of Control Structures in Programming:

Control structures are what make programs dynamic and intelligent. Their application is essential for:

- ✓ **Creating Complex Logic:** Allowing programs to handle intricate decision-making processes and perform sophisticated sequences of actions.
- ✓ **Developing Interactive Applications:** Enabling programs to respond to user input and events in a meaningful way.
- ✓ **Automating Repetitive Tasks:** Saving time and effort by allowing programs to perform the same operations multiple times.
- ✓ **Implementing Algorithms:** Providing the tools to translate abstract algorithms into concrete, executable code.
- ✓ **Building Efficient Solutions:** Choosing the right control structure can significantly impact the performance and efficiency of a program.
- ✓ **Handling Different Scenarios:** Allowing programs to adapt their behavior based on varying conditions and data.
- ✓ **Developing Real-World Applications:** Virtually all non-trivial software applications rely heavily on the effective use of control structures to implement their functionality.

From simple scripts to complex operating systems and artificial intelligence algorithms, control structures are the fundamental mechanisms that dictate how a computer program behaves and solves problems. Understanding and applying them effectively is a core skill in computer programming.

3.4.5 How Boolean Expressions are Used in Programming

(Key Inquiry Question 1: How are Boolean expressions used in programming?)

Boolean expressions are expressions that evaluate to either `True` or `False`. They are fundamental to control structures, particularly selection and iteration:

- ✚ **Condition Evaluation:** In `if` statements and `while` loops, a Boolean expression is evaluated to determine whether the block of code within the structure should be executed.
 - `if condition`:: The code block is executed if `condition` is `True`.
 - `while condition`:: The code block is executed repeatedly as long as `condition` is `True`.
- ✚ **Combining Conditions:** Logical operators (`and`, `or`, `not`) are used to create more complex Boolean expressions by combining simpler ones.
 - `if age > 18 and has_voted`:: Both conditions must be true.
 - `if is_student or is_employed`:: At least one condition must be true.
 - `if not is_admin`:: The condition `is_admin` must be false.
- ✚ **Storing Logical States:** Boolean variables can be used to store the result of a Boolean expression and used later in control structures.

Python

```
is_valid = (user_input == "yes")
if is_valid:
    # ... do something
```

- ✚ **Controlling Loop Termination:** The condition in a `while` loop is a Boolean expression that determines when the loop will stop executing.
- ✚ **Returning Logical Values from Functions:** Functions can be designed to return Boolean values, which can then be used in control structures.

Python

```
def is_even(number):
    return number % 2 == 0

if is_even(10):
    print("10 is even")
```

In essence, Boolean expressions provide the logical foundation for decision-making and repetition in programs, allowing them to behave conditionally and iteratively based on the evaluation of these expressions.

3.4.6 Importance of Control Structures in Programming

This is largely covered in 3.4.4,

Control structures are of paramount importance in programming because they:

- ✓ **Enable Non-Linear Execution:** They allow programs to deviate from a simple sequential flow, making them capable of performing complex tasks.
- ✓ **Implement Algorithms:** Any algorithm that involves decision-making or repetition requires the use of control structures in its programming implementation.
- ✓ **Create Dynamic and Interactive Programs:** Control structures allow programs to respond to different inputs and user actions, making them interactive.

- ✓ **Automate Tasks Efficiently:** Loops enable the efficient repetition of code, automating tasks that would be tedious or impossible to do manually.
- ✓ **Manage Complexity:** By structuring the flow of execution, control structures help in organizing code and managing the complexity of software development.
- ✓ **Form the Basis of Computational Logic:** They are the fundamental building blocks for implementing logical reasoning and decision-making within computer programs.

SUB-STRAND 3.5: DATA STRUCTURES (14 Lessons)

3.5.1 Types of Containers in Programming

(a) Describe Types of Containers in Programming:

In programming, containers (also known as data structures) are ways to store and organize collections of data. Different containers have different characteristics that make them suitable for various tasks. Here are some common types:

- ✚ **Lists (Arrays - conceptually similar in many languages):** Ordered collections of items. Elements in a list can be of different data types. Lists are mutable, meaning their elements can be changed, added, or removed after creation. In some languages, a more restrictive ordered collection of elements of the same data type might be referred to as an array.
 - ✓ **Example (Python List):** `[1, 2, "hello", 3.14, True]`
 - ✓ **Characteristics:** Ordered, mutable, can contain different data types.
- ✚ **Arrays (in languages like C++, Java):** Ordered collections of items of the *same* data type. The size of an array is usually fixed at the time of creation.
 - ✓ **Example (Java Array):** `int[] numbers = {1, 2, 3, 4, 5};`
 - ✓ **Characteristics:** Ordered, usually fixed size, elements of the same data type.
- ✚ **Dictionaries (Hash Maps or Associative Arrays):** Collections of key-value pairs. Each key is unique and is used to access its corresponding value. Dictionaries are unordered (in older Python versions, ordered in newer ones) and mutable.
 - ✓ **Example (Python Dictionary):** `{"name": "Alice", "age": 30, "city": "Nairobi"}`
 - ✓ **Characteristics:** Key-value pairs, keys are unique, mutable, unordered (initially).
- ✚ **Sets:** Unordered collections of unique elements. Sets do not allow duplicate values. They support mathematical set operations like union, intersection, and difference. Sets are mutable.
 - ✓ **Example (Python Set):** `{1, 2, 3, 4, 5}`
 - ✓ **Characteristics:** Unordered, contains only unique elements, mutable.
- ✚ **Tuples:** Ordered collections of items, similar to lists. However, tuples are immutable, meaning their elements cannot be changed, added, or removed after creation.
 - ✓ **Example (Python Tuple):** `(1, 2, "hello", 3.14, True)`
 - ✓ **Characteristics:** Ordered, immutable, can contain different data types.
- ✚ **Classes (as containers of attributes):** While primarily used for object-oriented programming, classes can be seen as containers that hold data (attributes or variables) and functions (methods) that operate on that data. Objects are instances of classes.
 - ✓ **Example (Python Class):**

Python

```

class Person:
    def __init__(self, name, age):
        self.name = name
        self.age = age
person1 = Person("Bob", 25)

```

✓ **Characteristics:** Can hold various types of data and functions, used to create objects.

✚ **Abstract Data Types (ADTs):** These are conceptual descriptions of how data is organized and the operations that can be performed on it, without specifying a particular implementation. Examples include stacks, queues, trees, and graphs. These are often implemented using the concrete container types mentioned above.

✓ **Example (Stack - conceptually):** Follows the Last-In, First-Out (LIFO) principle. Operations include push (add to top) and pop (remove from top). Can be implemented using a list.

✓ **Example (Queue - conceptually):** Follows the First-In, First-Out (FIFO) principle. Operations include enqueue (add to rear) and dequeue (remove from front). Can be implemented using a list or a dedicated queue data structure.

3.5.2 Using Containers in Programming

(b) Use Containers in Programming:

Using containers involves declaring, initializing, accessing, and manipulating the data stored within them based on their specific properties and the syntax of the programming language.

➤ Declaration and Initialization:

✓ Lists (Python):

Python

```

my_list = [] # Empty list
numbers = [10, 20, 30, 40]
mixed = [1, "two", 3.0]

```

✓ **Arrays (conceptual - similar to lists in Python):** (See above)

✓ Dictionaries (Python):

Python

```

student = {"name": "Charlie", "grade": 11}
empty_dict = {}

```

✓ Sets (Python):

Python

```

my_set = {1, 2, 3}
empty_set = set()

```

✓ **Tuples (Python):**

Python

```
my_tuple = (1, 2, 3)
empty_tuple = ()
single_item_tuple = (5,) # Note the comma
```

➤ **Accessing Elements:**

✓ **Lists and Tuples (by index - starting from 0):**

Python

```
numbers = [10, 20, 30]
first_element = numbers[0] # 10
second_element = numbers[1] # 20
last_element = numbers[-1] # 30
```

✓ **Dictionaries (by key):**

Python

```
student = {"name": "Charlie", "grade": 11}
name = student["name"] # "Charlie"
grade = student["grade"] # 11
```

✓ **Sets (cannot access directly by index):** You typically iterate through a set or check for membership.

Python

```
my_set = {1, 2, 3}
for item in my_set:
    print(item)
is_present = 2 in my_set # True
```

➤ **Manipulation (for mutable containers):**

✓ **Lists (Python):**

Python

```
my_list = [1, 2, 3]
my_list.append(4) # [1, 2, 3, 4]
my_list.insert(0, 0) # [0, 1, 2, 3, 4]
my_list.remove(2) # [0, 1, 3, 4]
del my_list[1] # [0, 3, 4]
my_list[0] = -1 # [-1, 3, 4]
```

✓ **Dictionaries (Python):**

Python

```

student = {"name": "Charlie", "grade": 11}
student["age"] = 16      # Add a new key-value pair
student["grade"] = 12   # Update an existing value
del student["age"]     # Remove a key-value pair

```

✓ **Sets (Python):**

Python

```

my_set = {1, 2, 3}
my_set.add(4)          # {1, 2, 3, 4}
my_set.remove(2)      # {1, 3, 4}
my_set.discard(5)     # Removes if present, no error if not

```

✓ **Tuples (immutable - cannot be changed after creation):**

➤ **Iteration:** You can loop through the elements of most containers.

✓ **Lists and Tuples:**

Python

```

numbers = [1, 2, 3]
for num in numbers:
    print(num)

```

✓ **Dictionaries (iterating through keys, values, or items):**

Python

```

student = {"name": "Charlie", "grade": 11}
for key in student:
    print(key)          # Prints keys
for value in student.values():
    print(value)       # Prints values
for key, value in student.items():
    print(key, value)  # Prints key-value pairs

```

✓ **Sets:** (See accessing elements)

3.5.3 Applying Sorting and Searching Techniques in Data Structures

(c) Apply Sorting and Searching Techniques in Data Structures:

Sorting and searching are common operations performed on data structures to organize and find specific elements efficiently.

- **Searching Techniques:**

- ✓ **Sequential Search (Linear Search):** Examines each element in the container one by one until the target element is found or the end of the container is reached. Simple but can be inefficient for large, unsorted containers.

Python

```
def sequential_search(data, target):
    for index, item in enumerate(data):
        if item == target:
            return index
    return -1

my_list = [5, 2, 8, 1, 9]
index = sequential_search(my_list, 8) # Returns 2
```

- ✓ **Binary Search:** An efficient algorithm for finding an element in a *sorted* container. It repeatedly divides the search interval in half. If the middle element is the target, the search is complete. If the target is smaller, the search continues in the left half; if larger, in the right half.

Python

```
def binary_search(data, target):
    low = 0
    high = len(data) - 1
    while low <= high:
        mid = (low + high) // 2
        if data[mid] == target:
            return mid
        elif data[mid] < target:
            low = mid + 1
        else:
            high = mid - 1
    return -1

sorted_list = [1, 2, 5, 8, 9]
index = binary_search(sorted_list, 8) # Returns 3
```

- **Sorting Techniques:** Algorithms used to arrange the elements of a container in a specific order (e.g., ascending or descending).
 - ✓ **Insertion Sort:** Builds the final sorted array one item at a time. It iterates through the input elements and inserts each element into its correct position in the sorted part of the array. Efficient for small datasets or nearly sorted data.

Python

```
def insertion_sort(data):
    for i in range(1, len(data)):
        key = data[i]
        j = i - 1
        while j >= 0 and key < data[j]:
            data[j + 1] = data[j]
            j -= 1
        data[j + 1] = key

my_list = [5, 2, 8, 1, 9]
insertion_sort(my_list) # my_list becomes [1, 2, 5, 8, 9]
```

- ✓ **Selection Sort:** Repeatedly finds the minimum element from the unsorted part of the array and swaps it with the element at the beginning of the unsorted part. Simple but generally less efficient than insertion sort for larger datasets.

Python

```
def selection_sort(data):
    for i in range(len(data)):
        min_index = i
        for j in range(i + 1, len(data)):
            if data[j] < data[min_index]:
                min_index = j
        data[i], data[min_index] = data[min_index], data[i]

my_list = [5, 2, 8, 1, 9]
selection_sort(my_list) # my_list becomes [1, 2, 5, 8, 9]
```

- ✓ **Bubble Sort:** Repeatedly steps through the list, compares adjacent elements and swaps them if they are in the wrong order. Passes through the list are repeated until the list is sorted. Simple to understand but inefficient for large datasets.

```
def bubble_sort(data):
    n = len(data)
    for i in range(n - 1):
        for j in range(n - i - 1):
            if data[j] > data[j + 1]:
                data[j], data[j + 1] = data[j + 1], data[j]
```

```
my_list = [5, 2, 8, 1, 9]
bubble_sort(my_list) # my_list becomes [1, 2, 5, 8, 9]
```

* **Quick Sort:** A highly efficient, divide-and-conquer sorting algorithm. It picks an element as a pivot and partitions the array around the pivot. Elements smaller than the pivot are placed before it, and elements greater than the pivot are placed after it. This process is recursively applied to the sub-arrays. Generally faster than insertion sort, selection sort, and bubble sort for large datasets.

```
python
def quick_sort(data):
    if len(data) <= 1:
        return data
    pivot = data[len(data) // 2]
    left = [x for x in data if x < pivot]
    middle = [x for x in data if x == pivot]
    right = [x for x in data if x > pivot]
    return quick_sort(left) + middle + quick_sort(right)

my_list = [5, 2, 8, 1, 9]
sorted_list = quick_sort(my_list) # sorted_list is [1, 2, 5, 8, 9]
```

3.5.4 Embracing the Use of Containers in Programming

(d) Embrace the Use of Containers in Programming:

Containers are essential tools in programming, and understanding their use is crucial for effective software development. They offer numerous benefits:

- ✓ **Organization of Data:** Containers provide structured ways to store and manage collections of related data, making programs more organized and easier to understand.
- ✓ **Efficient Data Access and Manipulation:** Different container types are optimized for specific operations, allowing for efficient access, insertion, deletion, and modification of data. For example, dictionaries provide fast lookups based on keys.
- ✓ **Flexibility:** Containers can hold various types of data (in some languages), allowing for the creation of versatile data structures.
- ✓ **Abstraction:** Abstract data types (like stacks and queues) provide a high-level way to think about data organization and operations, hiding the underlying implementation details.
- ✓ **Algorithm Implementation:** Many algorithms rely on specific data structures for their efficient implementation (e.g., binary search requires a sorted list or array).
- ✓ **Code Reusability:** Standard container types are often provided by programming languages as built-in features or libraries, promoting code reusability and reducing development time.
- ✓ **Solving Complex Problems:** Containers enable the creation of sophisticated data models that can represent complex relationships and facilitate the solution of real-world problems.

3.5.5 Why are Data Containers Used in Programming?

Data containers are used in programming for several critical reasons:

- ✓ **To Store Collections of Data:** Programs often need to work with multiple pieces of related data. Containers provide a way to group these items together under a single name.
- ✓ **To Organize Data:** Containers provide structure to data, making it easier to manage and access. Different structures offer different ways of organizing data (e.g., ordered lists, key-value pairs).
- ✓ **To Efficiently Access and Manipulate Data:** The choice of container can significantly impact how efficiently data can be accessed, inserted, deleted, and modified. For example, accessing an element by index in a list or by key in a dictionary is typically very fast.
- ✓ **To Implement Algorithms:** Many algorithms require specific ways of organizing data. For instance, sorting algorithms work on ordered collections, and graph algorithms use structures to represent nodes and edges.
- ✓ **To Abstract Data Management:** Abstract data types allow programmers to focus on the logical operations on data without worrying about the underlying implementation details.
- ✓ **To Reuse Code:** Programming languages provide built-in container types and libraries, allowing programmers to reuse well-tested and efficient data structures.
- ✓ **To Model Real-World Entities:** Containers can be used to represent collections of objects or entities from the real world in a program.

SUB-STRAND 3.6: FUNCTIONS (14 Lessons)

3.6.1 Types of Functions in Modular Programming

(a) Discuss Types of Functions Used in Modular Programming:

In programming, functions (also known as subroutines, procedures, or methods) are blocks of reusable code that perform a specific task. Modular programming is a software design technique that emphasizes separating the functionality of a program into independent, interchangeable modules, where each module contains everything necessary to execute only one aspect of the desired functionality. Functions are the primary building blocks of modular programs.

There are two main types of functions:

- **Built-in Functions (Predefined Functions):** These are functions that are provided by the programming language itself or its standard libraries. They are readily available for use without the need for explicit definition by the programmer. These functions perform common and frequently needed tasks.

- ✚ **Examples (Python):**

- ✓ `print()`: Displays output to the console.
- ✓ `len()`: Returns the number of items in a sequence (like a list or string).
- ✓ `input()`: Reads input from the user.
- ✓ `type()`: Returns the data type of an object.
- ✓ `math.sqrt()`: Calculates the square root (from the `math` module).
- ✓ `str()`, `int()`, `float()`: Functions for type conversion.

- ✚ **Characteristics:** Provided by the language or its libraries, ready to use, perform specific common tasks.

- **User-Defined Functions:** These are functions that are created by the programmer to perform specific tasks that are not covered by built-in functions or to organize the program's logic into reusable blocks.

- ✚ **Example (Python):**

Python

```
def greet(name):  
    print(f"Hello, {name}!")  
  
def calculate_area(length, width):  
    area = length * width  
    return area
```

- ✚ **Characteristics:** Defined by the programmer, perform specific tasks relevant to the program's requirements, promote code reusability and modularity.

3.6.2 Using Built-in and User-Defined Functions

(b) Use Built-in and User-Defined Functions to Create a Modular Program:

Creating a modular program involves breaking down the program's functionality into a set of functions (both built-in and user-defined) that work together to achieve the overall goal.

- ✓ **Using Built-in Functions:** Simply call the function by its name, providing any required arguments.
- **Example (Python):**

Python

```

user_name = input("Enter your name: ") # Using the built-in input() function
length = 5
width = 10
area = length * width
print("The area is:", area) # Using the built-in print() function
number_of_letters = len(user_name) # Using the built-in len() function
print(f"Your name has {number_of_letters} letters.")

```

- ✓ **Using User-Defined Functions:** First, define the function with a name, parameters (if any), and a block of code that performs the task. Then, call the function by its name, providing the necessary arguments.

- **Example (Python - Modular Program):**

Python

```

# User-defined function to greet
def greet(name):
    print(f"Hello, {name}!")

# User-defined function to calculate area
def calculate_rectangle_area(length, width):
    area = length * width
    return area

# Main part of the program (modular structure using functions)
user_name = input("Enter your name: ")
greet(user_name) # Calling the user-defined greet() function

length = float(input("Enter the length of the rectangle: "))
width = float(input("Enter the width of the rectangle: "))
rectangle_area = calculate_rectangle_area(length, width) # Calling
calculate_rectangle_area()
print("The area of the rectangle is:", rectangle_area)

```

In this example, the program's logic is divided into two user-defined modules (`greet` and `calculate_rectangle_area`) and uses built-in functions (`input`, `print`, `float`) to interact with the user and display results. This modular structure makes the code more organized, readable, and reusable.

3.6.3 Scope of Variables and Parameter Passing

(c) Discuss the Scope of Variables and Parameter Passing Between Functions:

- **Scope of Variables:** The scope of a variable refers to the region of the program where that variable can be accessed (used or modified). There are two main types of scope:
 - ✓ **Local Scope:** Variables that are defined inside a function have local scope. They can only be accessed from within that function. Once the function finishes execution, these local variables are destroyed, and their values are no longer accessible from outside the function.

- **Example (Python):**

Python

```
def my_function():
```

```

    local_var = 10
    print("Inside function:", local_var)

my_function() # Output: Inside function: 10
# print(local_var) # This would cause an error (NameError: name
'local_var' is not defined)

```

- ✓ **Global Scope:** Variables that are defined outside of any function have global scope. They can be accessed from anywhere in the program, including inside functions. However, to modify a global variable from within a function in some languages (like Python), you might need to use a special keyword (e.g., `global`).

- ✚ **Example (Python):**

Python

```

global_var = 20

def another_function():
    print("Inside function:", global_var)

another_function() # Output: Inside function: 20
print("Outside function:", global_var) # Output: Outside function: 20

def modify_global():
    global global_var
    global_var = 30

modify_global()
print("After modification:", global_var) # Output: After modification: 30

```

- **Parameter Passing Between Functions:** Functions often need to receive data from the calling part of the program to perform their tasks. This is done through parameters.
 - ✓ **Formal Parameters:** These are the variables listed in the function definition's parentheses. They act as placeholders for the values that will be passed to the function when it is called.
 - ✚ **Example (Python):** In `def calculate_area(length, width):`, `length` and `width` are formal parameters.
 - ✓ **Actual Parameters (Arguments):** These are the actual values or variables that are passed to the function when it is called. They correspond to the formal parameters in the function definition.
 - ✚ **Example (Python):** In `rectangle_area = calculate_area(5, 10)`, `5` is passed as the actual parameter for `length`, and `10` is passed as the actual parameter for `width`.
 - ✓ **Return Types:** Functions can optionally return a value back to the part of the program that called them using the `return` statement. The data type of the returned value is the return type of the function. If a function does not have a `return` statement, or if it has `return` without a value, it typically returns a special value (e.g., `None` in Python).
 - ✚ **Example (Python):** `calculate_area` has a return type that is the result of `length * width`.
 - ✓ **Function Prototype/Signature:** This specifies the function's name, the number and types of its parameters, and its return type (if any). It provides the interface of the function, indicating how it can be called and what to expect from it.

✚ **Example (Conceptual):** For `def calculate_area(length: float, width: float) -> float:`, the signature indicates a function named `calculate_area` that takes two float parameters (`length` and `width`) and returns a float value.

✓ **How Data is Passed:**

- ✚ **Pass by Value:** In some languages, when an argument is passed by value, a copy of the actual parameter's value is created and passed to the formal parameter. Changes made to the formal parameter inside the function do not affect the original actual parameter.
- ✚ **Pass by Reference (or Pass by Address):** In other languages, or for certain data types, when an argument is passed by reference (or address), the formal parameter becomes an alias for the actual parameter. Changes made to the formal parameter inside the function directly affect the original actual parameter.
- ✚ **Pass by Object Reference (in Python):** Python uses a mechanism that is often described as "pass by object reference" or "call by sharing." For immutable objects (like numbers, strings, tuples), it behaves like pass by value. For mutable objects (like lists, dictionaries), changes made to the object within the function can affect the original object outside the function.

3.6.4 Appreciation of Modularity in Programming

(d) Appreciate the Importance of Modularity in Programming:

Modularity, achieved through the use of functions and other modular units (like modules or classes), is a crucial principle in software development for several reasons:

- ✓ **Code Reusability:** Functions can be called multiple times from different parts of the program, reducing code duplication and making the program more concise.
- ✓ **Improved Organization:** Breaking down a program into smaller, logical modules (functions) makes the code easier to understand, read, and navigate.
- ✓ **Easier Debugging and Testing:** Individual functions can be tested and debugged independently, making it easier to identify and fix errors.
- ✓ **Enhanced Maintainability:** Changes or bug fixes in one function are less likely to affect other parts of the program, making maintenance easier.
- ✓ **Increased Collaboration:** In large projects, different developers can work on different modules (functions) concurrently, improving development efficiency.
- ✓ **Abstraction:** Functions allow programmers to abstract away the details of a specific task. The calling code only needs to know what the function does, not how it does it.
- ✓ **Problem Decomposition:** Complex problems can be broken down into smaller, more manageable sub-problems, each of which can be implemented as a separate function.
- ✓ **Scalability:** Modular programs are generally easier to scale and extend with new features by adding new modules (functions) without significantly altering existing code.

3.6.5 What are the Roles of Functions in Modular Programming?

Functions play several key roles in modular programming:

- ✓ **Encapsulation:** Functions encapsulate a specific set of instructions that perform a particular task, hiding the implementation details from the rest of the program.

- ✓ **Abstraction:** They provide a higher level of abstraction, allowing programmers to think about the program in terms of tasks rather than individual low-level operations.
- ✓ **Code Organization:** Functions help to structure the program logically, making it easier to understand the flow of execution and the purpose of different code sections.
- ✓ **Reusability:** Once a function is defined, it can be called multiple times from different parts of the program, promoting code reuse and reducing redundancy.
- ✓ **Testability:** Individual functions can be tested in isolation to ensure they work correctly, simplifying the overall testing process.
- ✓ **Maintainability:** Changes or bug fixes within a function are typically isolated and less likely to affect other parts of the program.
- ✓ **Decomposition:** Functions facilitate the breaking down of complex problems into smaller, more manageable sub-problems, each handled by a separate function.

This CLASS notes have been prepared by following the curriculum design Developed by KICD

All rights reserved

